



**Projeto de Móveis - Câmara Municipal de Victor Graeff**  
**Planta Baixa Geral - 01**

**Arquiteta e Urbanista Tábara V. Petry**  
**CAU A64875-2**

Fone: 054 99172-0565 - email: arche\_arche@outlook.com - Av. Família Barth - 07 - Victor Graeff - RS



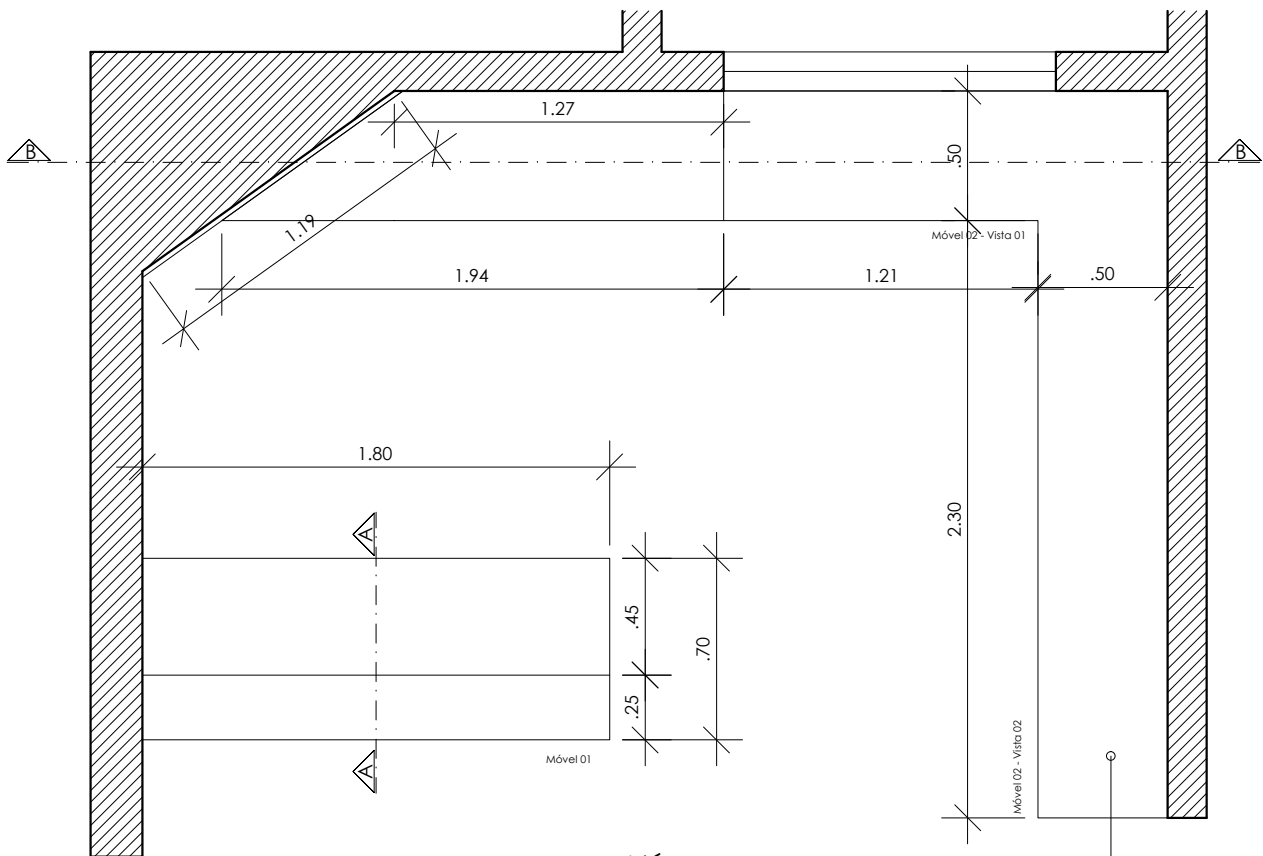

MÓVEL INICIA ALINHADO NA ABERTURA DA PORTA. CONFERIR METRAGEM DA PAREDE NA OBRA.

RECEPÇÃO

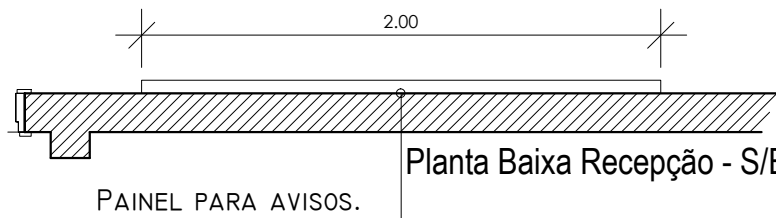

Planta Baixa Recepção - S/Escala

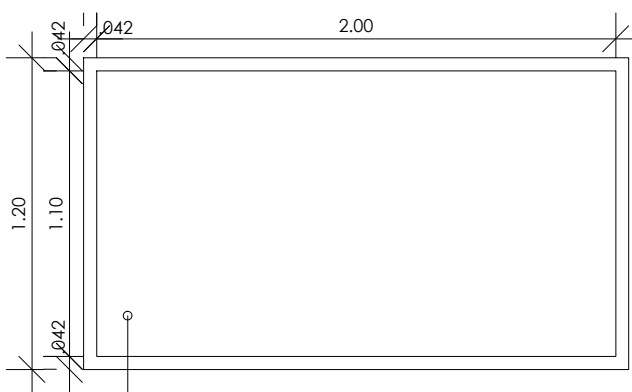

PAINEL PARA AVISOS. MORDURA EM LÂMINA DE MDF AMADEIRADA. FUNDO EM LÂMINA DE MDF NA COR BRANCA. ACIMA IRÁ SER COLADO TECIDO PARA ACABAMENTO.

Projeto de Móveis - Câmara Municipal de Victor Graeff  
Recepção - 02

Arquiteta e Urbanista Tábara V. Petry  
CAU A64875-2

Fone: 054 99172-0565 - email: arche\_arche@outlook.com - Av. Família Barth - 07 - Victor Graeff - RS



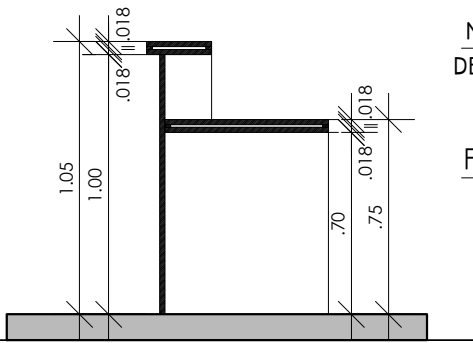

Corte AA Móvel 01 - Recepção

MÓVEL EM LÂMINA DE DE MDF NA COR LINHO CINZA.

FRENTE DO MÓVEL EM LÂMINA DE MDF AMADEIRADA.

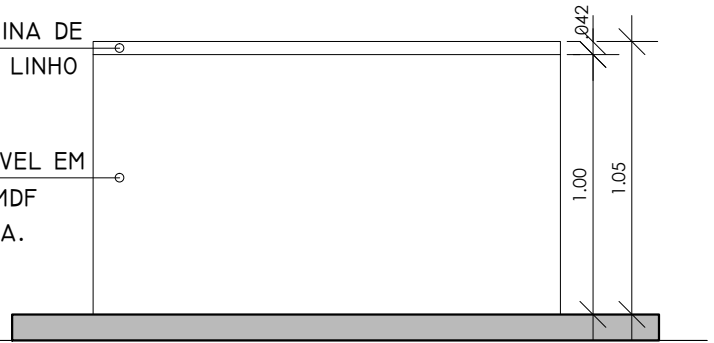

Vista Móvel 01 - Recepção

MÓVEL EM LÂMINA DE DE MDF NA COR LINHO CINZA.  
 ABERTURA DA GAVETA PELO SISTEMA CLICK. AS GAVETAS POSSUEM FECHAMENTO COM CHAVE. ABAIXO ESPAÇO PARA CPU.

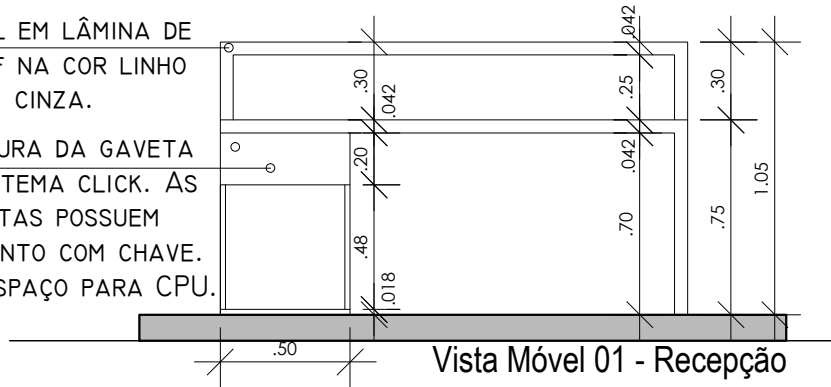

Vista Móvel 01 - Recepção

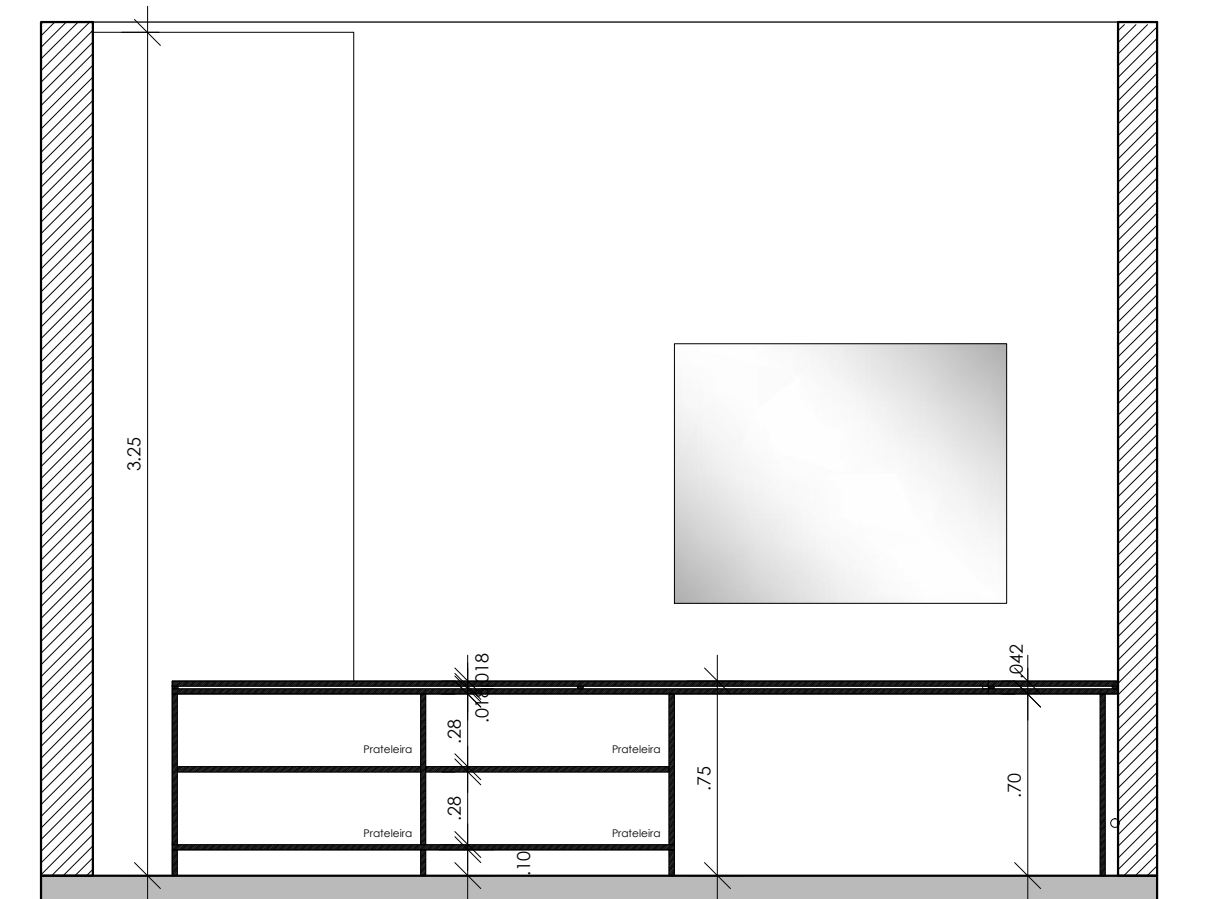

Corte BB Móvel 02- Recepção

Projeto de Móveis - Câmara Municipal de Victor Graeff  
 Recepção - 03

Arquiteta e Urbanista Tábara V. Petry  
 CAU A64875-2

Fone: 054 99172-0565 - email: arche\_arche@outlook.com - Av. Família Barth - 07 - Victor Graeff - RS



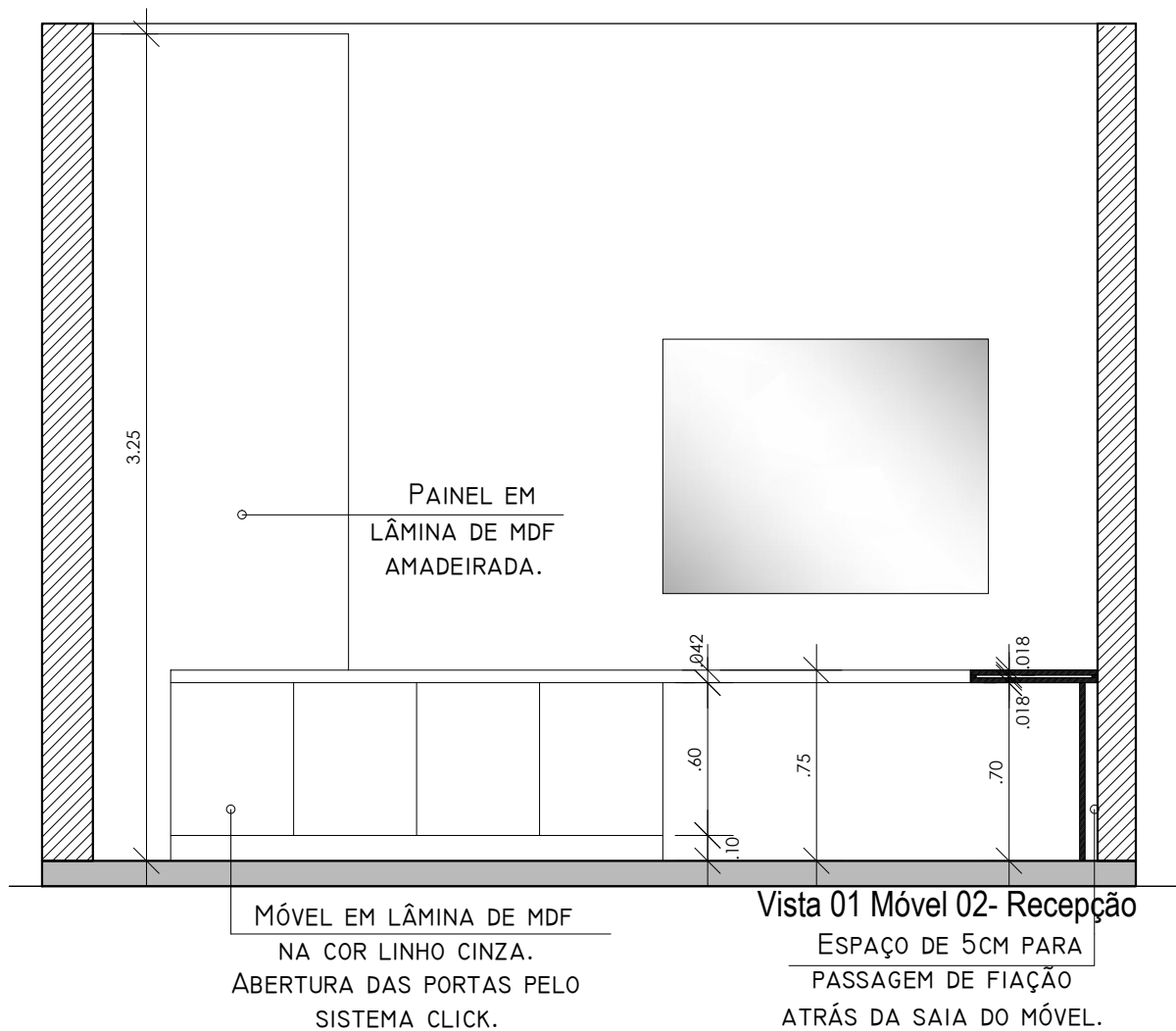

Projeto de Móveis - Câmara Municipal de Victor Graeff  
 Recepção - 04

Arquiteta e Urbanista Tábara V. Petry  
 CAU A64875-2

Fone: 054 99172-0565 - email: arche\_arche@outlook.com - Av. Família Barth - 07 - Victor Graeff - RS



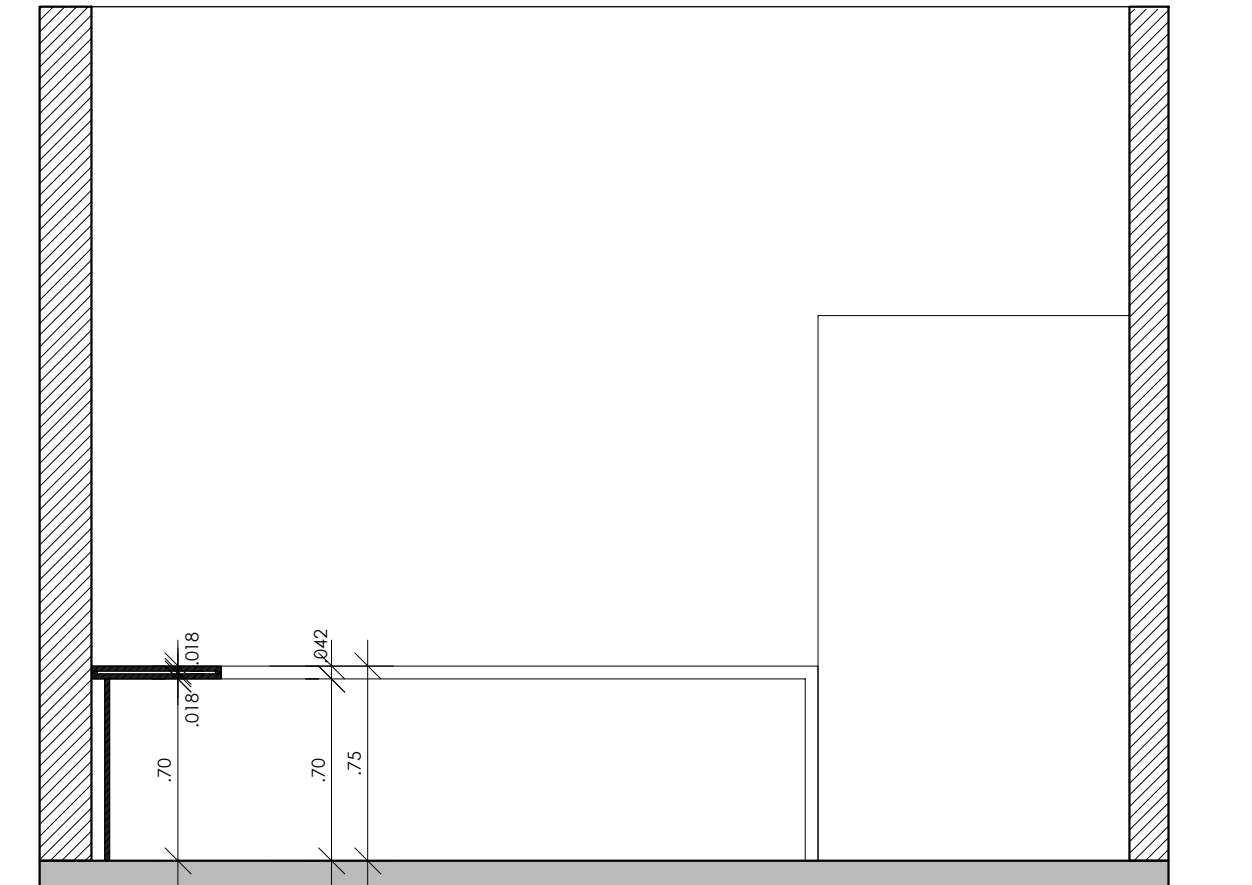

Vista 02 Móvel 02- Recepção



Projeto de Móveis - Câmara Municipal de Victor Graeff  
Recepção - 05

Arquiteta e Urbanista Tábara V. Petry  
CAU A64875-2

Fone: 054 99172-0565 - email: arche\_arche@outlook.com - Av. Família Barth - 07 - Victor Graeff - RS



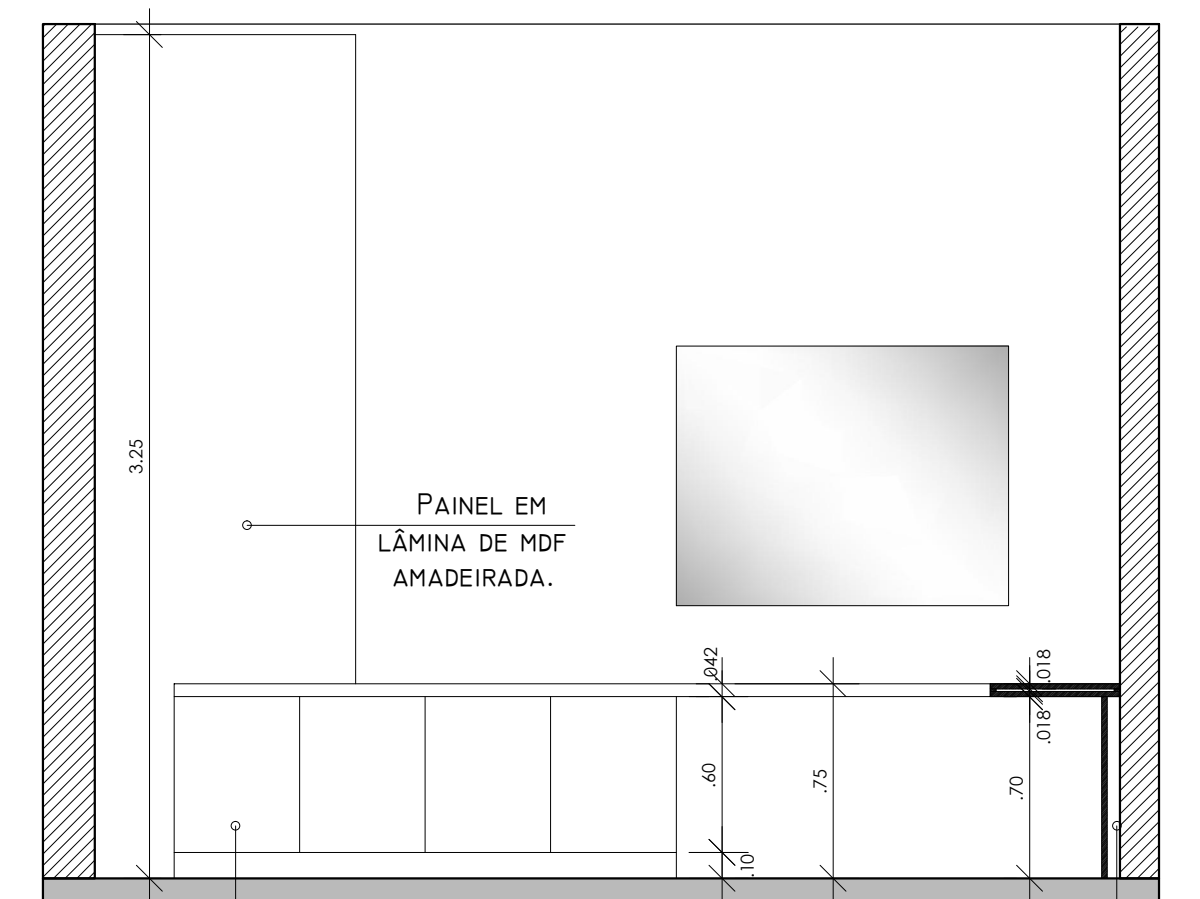

MÓVEL EM LÂMINA DE MDF  
NA COR LINHO CINZA.  
ABERTURA DAS PORTAS PELO  
SISTEMA CLICK.

Vista 01 Móvel 02- Recepção  
ESPAÇO DE 5CM PARA  
PASSAGEM DE FIAÇÃO  
ATRÁS DA SAIA DO MÓVEL.



Projeto de Móveis - Câmara Municipal de Victor Graeff  
Recepção - 06

Arquiteta e Urbanista Tábara V. Petry  
CAU A64875-2

Fone: 054 99172-0565 - email: arche\_arche@outlook.com - Av. Família Barth - 07 - Victor Graeff - RS



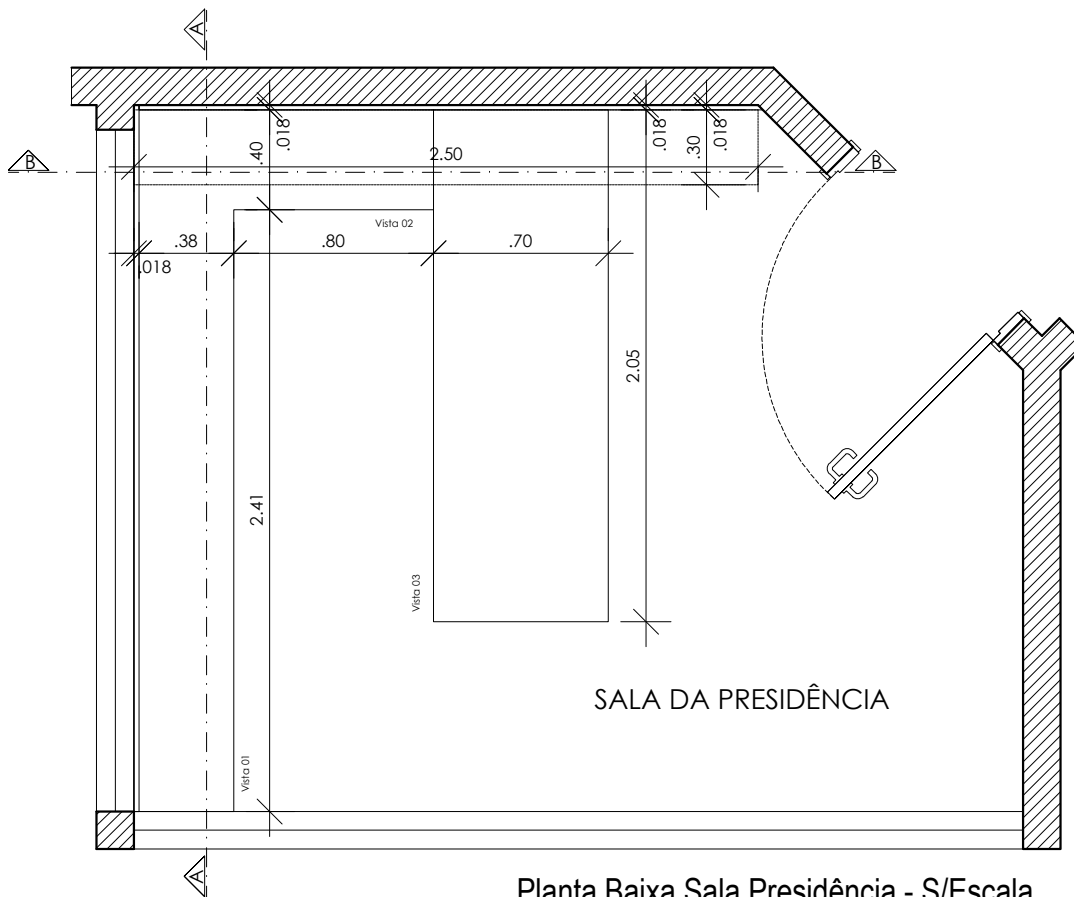

Planta Baixa Sala Presidência - S/Escala

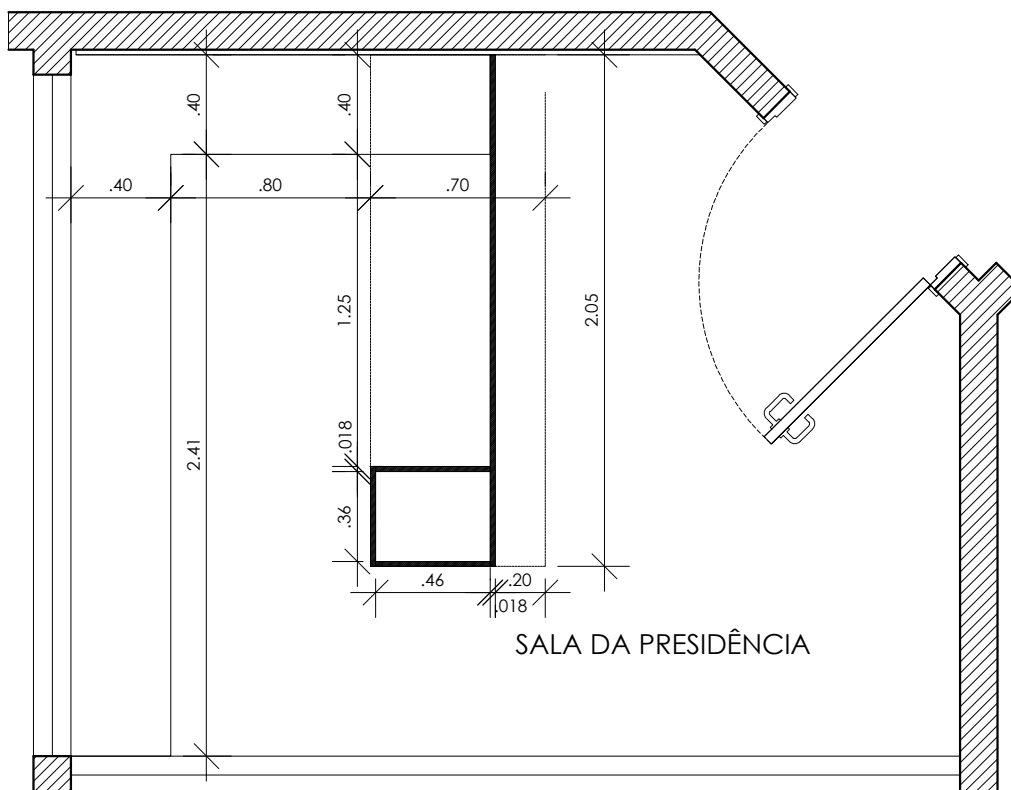

Planta Baixa Sala Presidência - S/Escala

Projeto de Móveis - Câmara Municipal de Victor Graeff  
Sala da Presidência - 07

Arquiteta e Urbanista Tábara V. Petry  
CAU A64875-2

Fone: 054 99172-0565 - email: arche\_arche@outlook.com - Av. Família Barth - 07 - Victor Graeff - RS













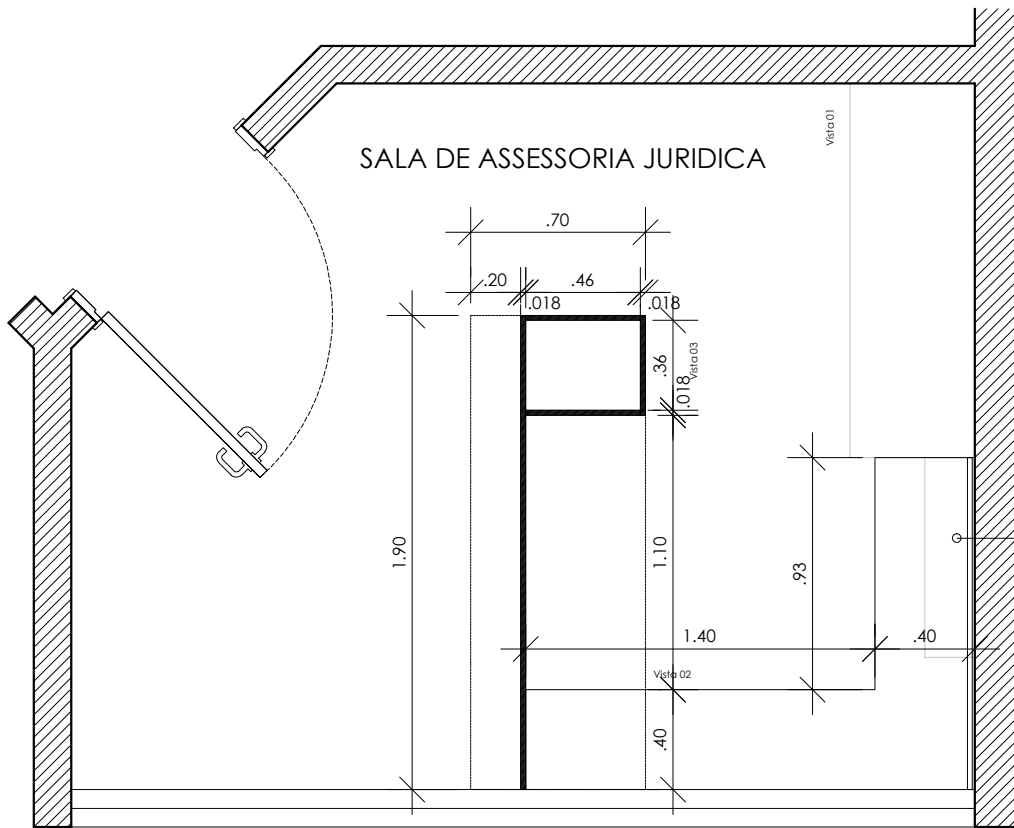

Planta Baixa Sala de Assessoria Juridica - S/Escala

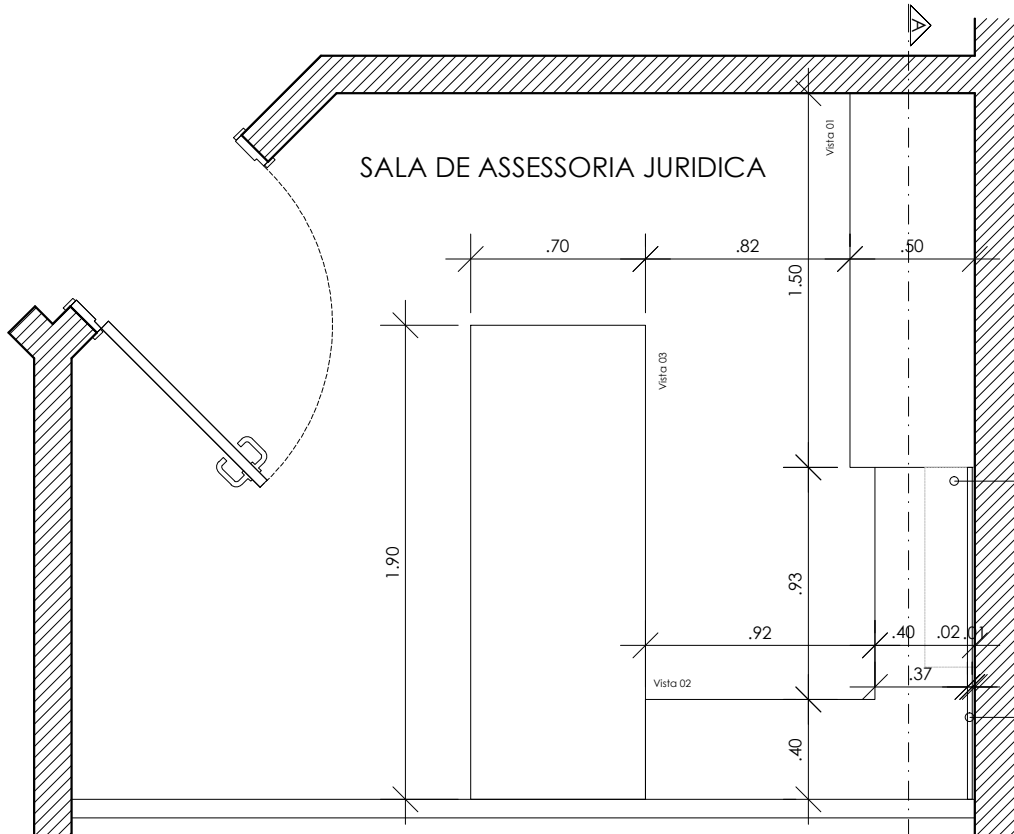

Planta Baixa Sala de Assessoria Juridica - S/Escala

Projeto de Móveis - Câmara Municipal de Victor Graeff  
Sala da Assessoria Juridica- 12

Arquiteta e Urbanista Tábara V. Petry  
CAU A64875-2

Fone: 054 99172-0565 - email: arche\_arche@outlook.com - Av. Família Barth - 07 - Victor Graeff - RS



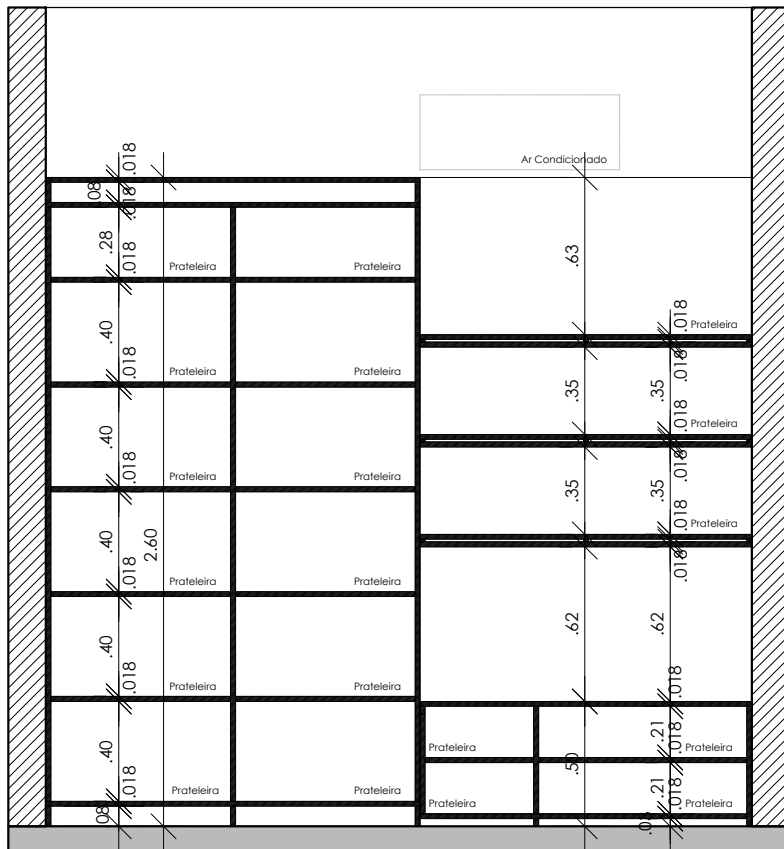

Corte AA Vista 01 - Sala de Assessoria Juridica



Projeto de Móveis - Câmara Municipal de Victor Graeff  
Sala da Assessoria Juridica - 13

Arquiteta e Urbanista Tábara V. Petry  
CAU A64875-2

Fone: 054 99172-0565 - email: arche\_arche@outlook.com - Av. Família Barth - 07 - Victor Graeff - RS



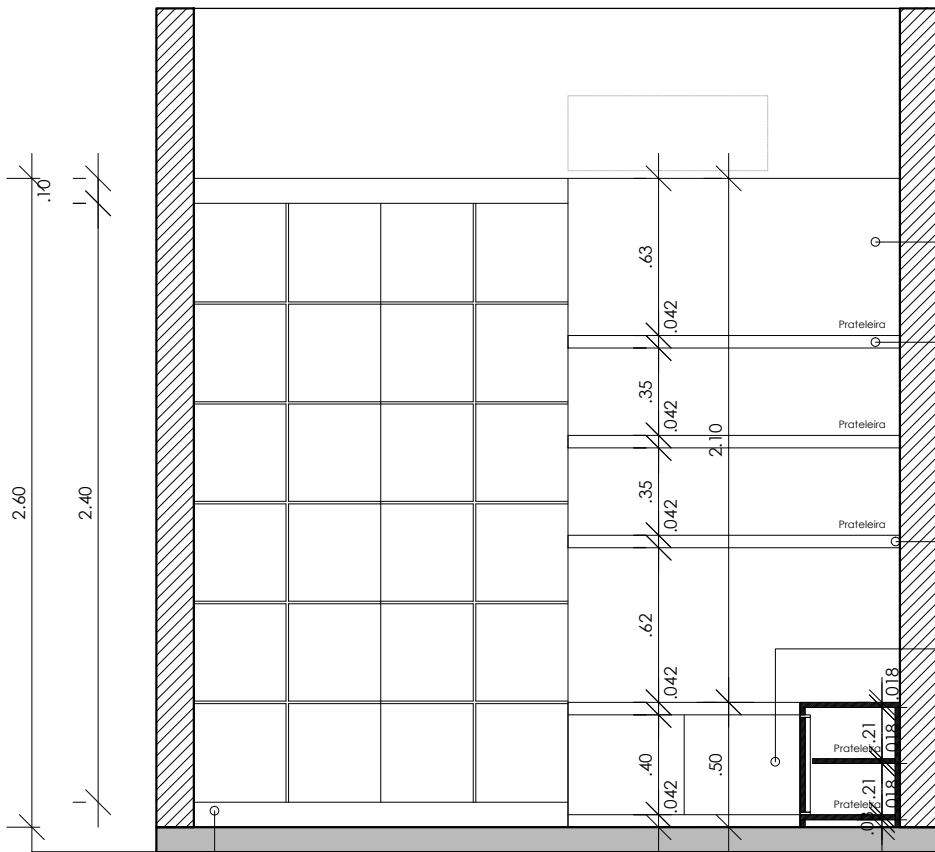

PAINEL EM LÂMINA DE MDF AMADEIRADA.

PRATELEIRAS EM LÂMINA DE MDF NA COR BRANCA.

PRATELEIRA INICIA NO PEITORIL DA JANELA.

ARMÁRIO EM LÂMINA DE MDF NA COR BRANCA. RODAPÉ EM LÂMINA AMADEIRADA. SISTEMA ABERTURA DAS PORTAS PELO SISTEMA CLICK. AS PORTAS LATERAIS POSSUEM O SISTEMA DE ABERTURA DE CORRER.

Vista 01 - Sala de Assessoria Juridica

ARMÁRIO EM LÂMINA DE MDF NA COR BRANCA. SISTEMA DE CORRER PARA ABERTURA DAS PORTAS. LÂMINA COM DETALHE QUADRICULADO COM NEGATIVO.



Projeto de Móveis - Câmara Municipal de Victor Graeff  
Sala da Assessoria Jurídica - 14

Arquiteta e Urbanista Tábara V. Petry  
CAU A64875-2

Fone: 054 99172-0565 - email: arche\_arche@outlook.com - Av. Família Barth - 07 - Victor Graeff - RS





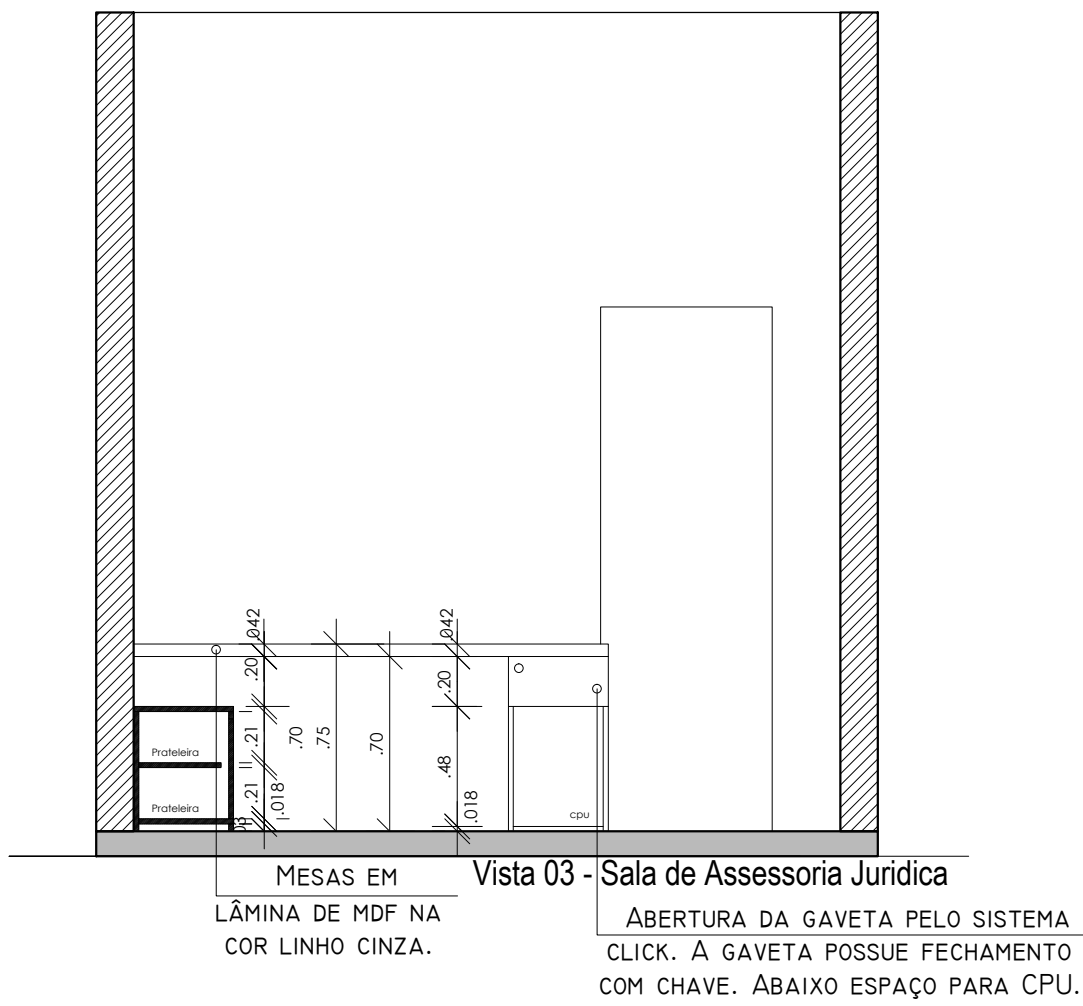

Projeto de Móveis - Câmara Municipal de Victor Graeff  
Sala da Assessoria Jurídica - 16

Arquiteta e Urbanista Tábara V. Petry  
CAU A64875-2

Fone: 054 99172-0565 - email: arche\_arche@outlook.com - Av. Família Barth - 07 - Victor Graeff - RS





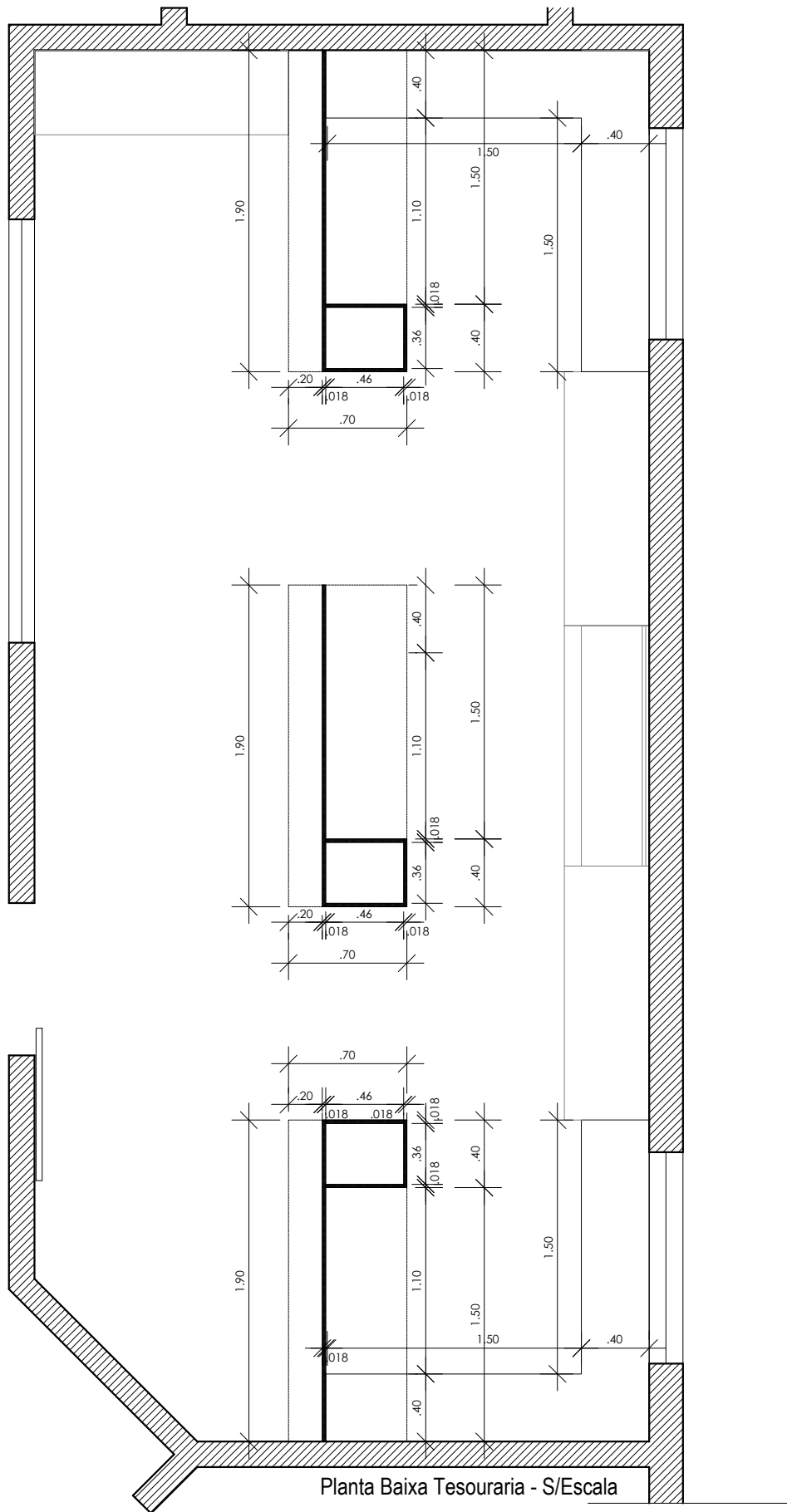

Projeto de Móveis - Câmara Municipal de Victor Graeff  
Sala da Tesouraria- 17

Arquiteta e Urbanista Tábara V. Petry  
CAU A64875-2

Fone: 054 99172-0565 - email: arche\_arche@outlook.com - Av. Família Barth - 07 - Victor Graeff - RS



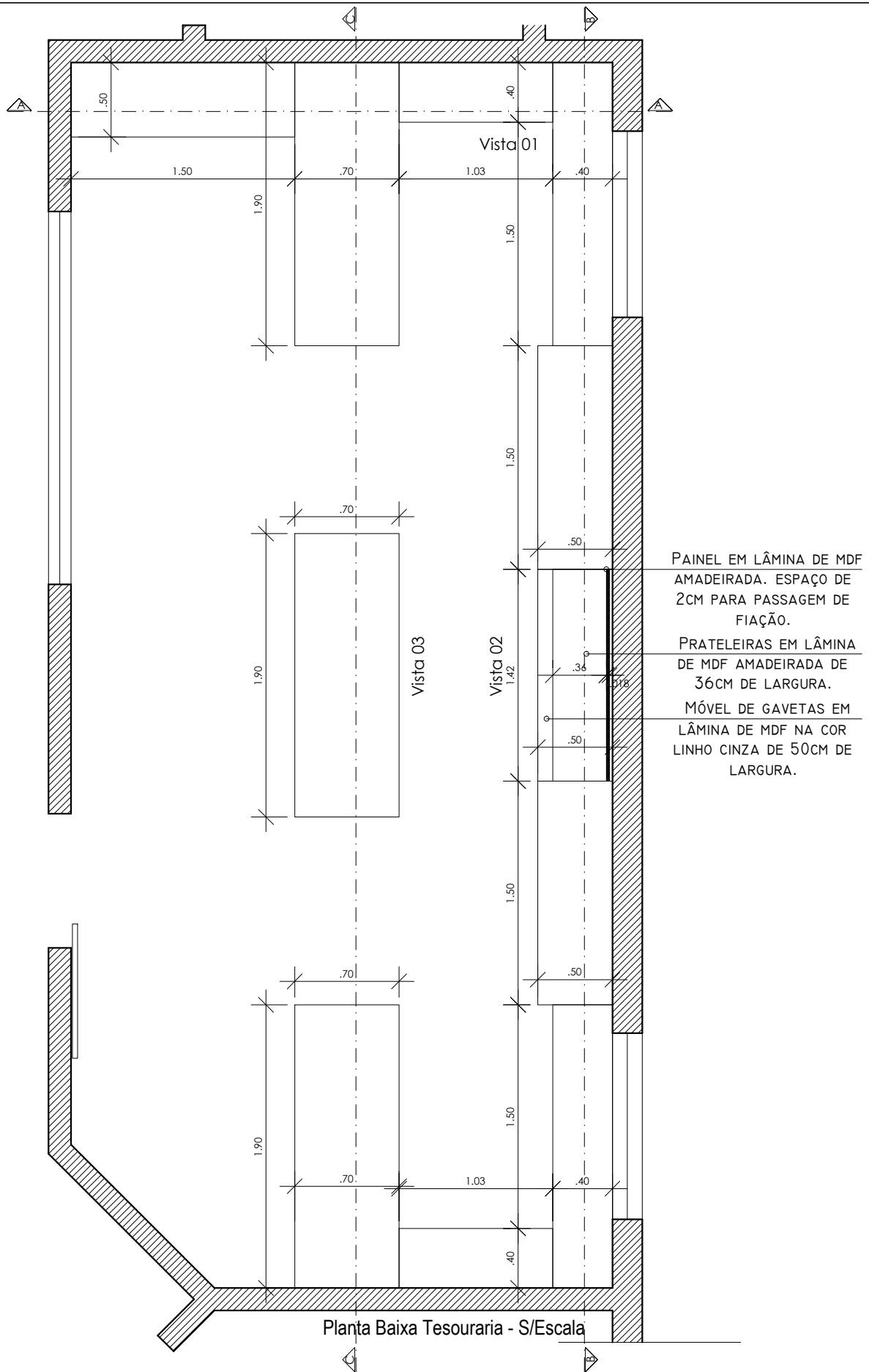

Projeto de Móveis - Câmara Municipal de Victor Graeff  
Sala da Tesouraria- 18

Arquiteta e Urbanista Tábara V. Petry  
CAU A64875-2

Fone: 054 99172-0565 - email: arche\_arche@outlook.com - Av. Família Barth - 07 - Victor Graeff - RS



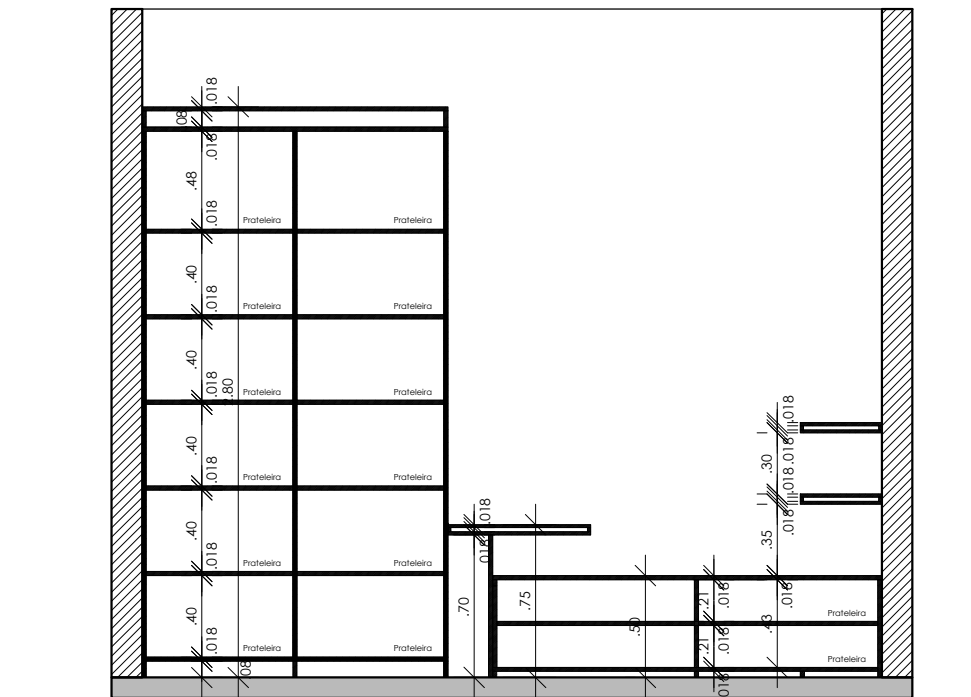

Corte AA Vista 01 - Sala da Tesouraria

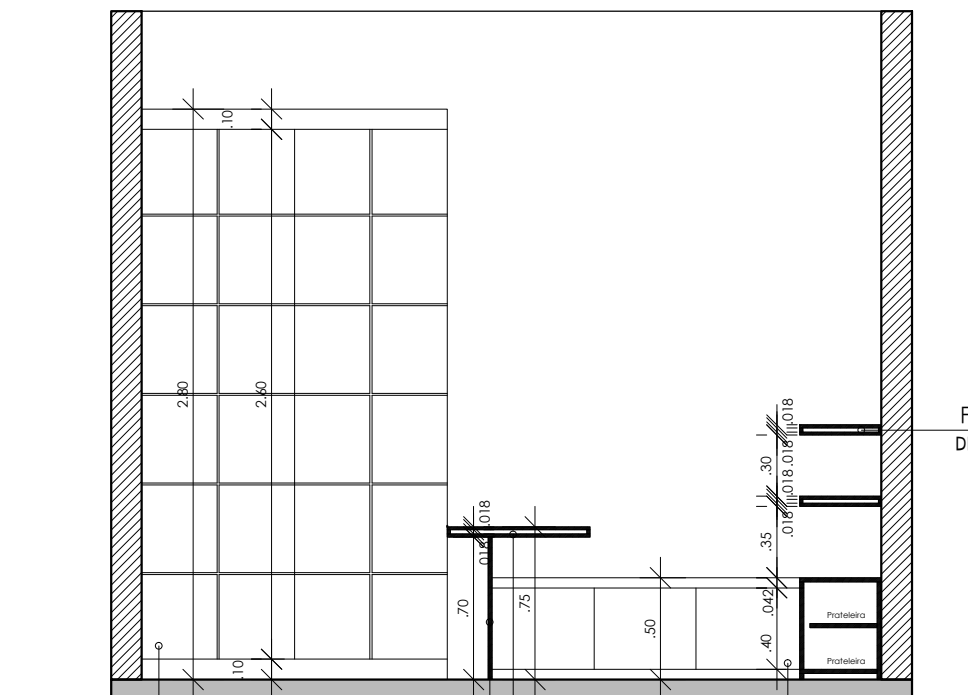

PRATELEIRAS EM LÂMINA DE MDF NA COR BRANCA.

Vista 01 - Sala da Tesouraria

ARMÁRIO EM LÂMINA DE MDF NA COR BRANCA. SISTEMA DE CORRER PARA ABERTURA DAS PORTAS. LÂMINA COM DETALHE QUADRICULADO COM NEGATIVO.

MESA EM LÂMINA DE MDF NA COR LINHO CINZA. SAIA DE FECHAMENTO DA MESA.

ARMÁRIO EM LÂMINA DE MDF NA COR BRANCA. RODAPÉ EM LÂMINA AMADEIRADA. AS PORTAS POSSUEM O SISTEMA DE ABERTURA DE CORRER.

Projeto de Móveis - Câmara Municipal de Victor Graeff  
Sala da Tesouraria- 19

Arquiteta e Urbanista Tábara V. Petry  
CAU A64875-2

Fone: 054 99172-0565 - email: arche\_arche@outlook.com - Av. Família Barth - 07 - Victor Graeff - RS



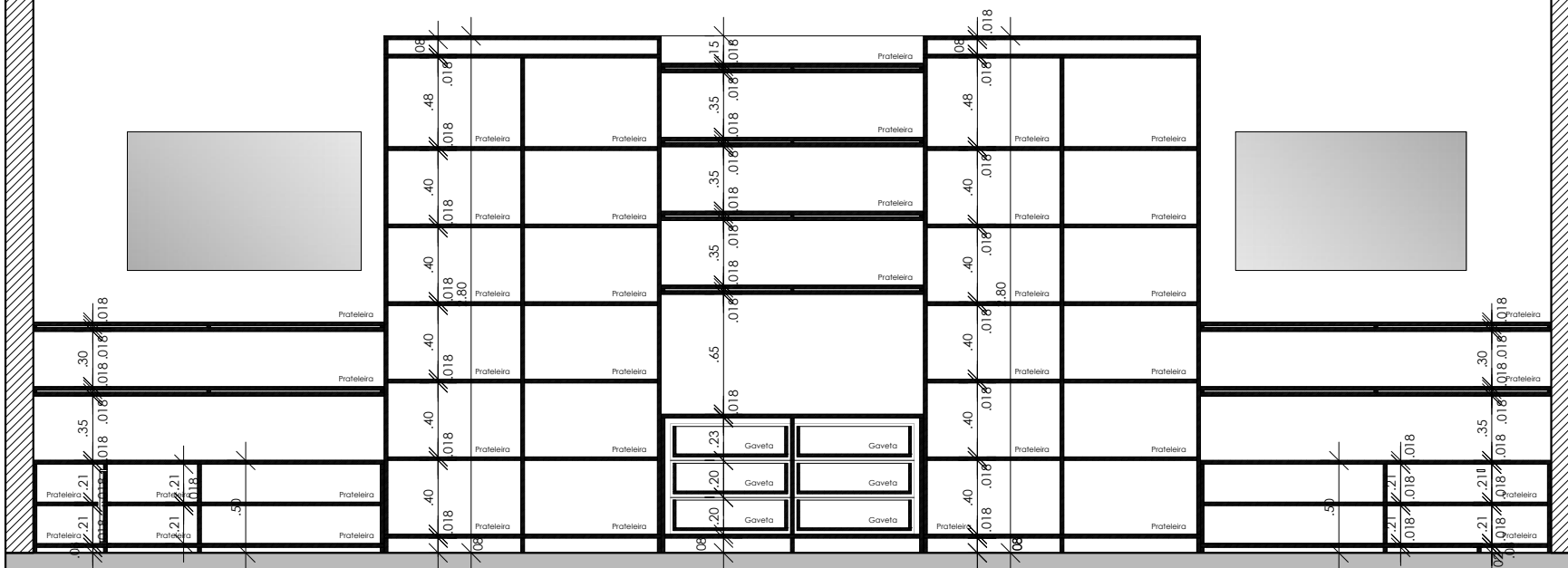

Corte BB Vista 02 - Sala da Tesouraria

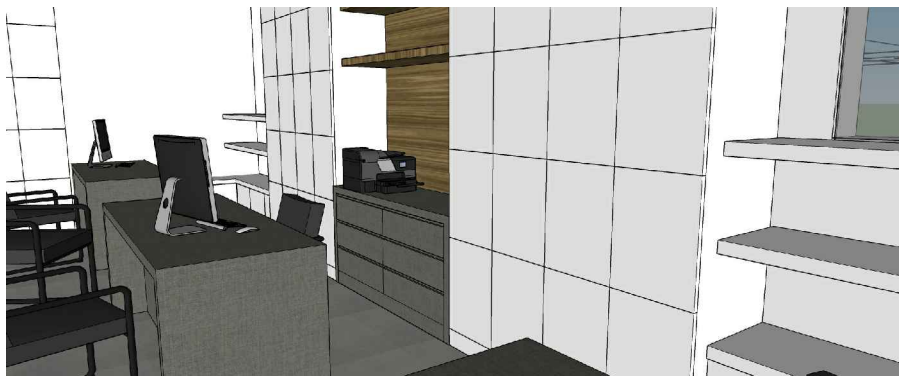

Projeto de Móveis - Câmara Municipal de Victor Graeff  
Sala da Tesouraria- 20

Arquiteta e Urbanista Tábora V. Petry  
CAU A64875-2

Fone: 054 99172-0565 - email: arche\_arche@outlook.com - Av. Família Barth - 07 - Victor Graeff - RS





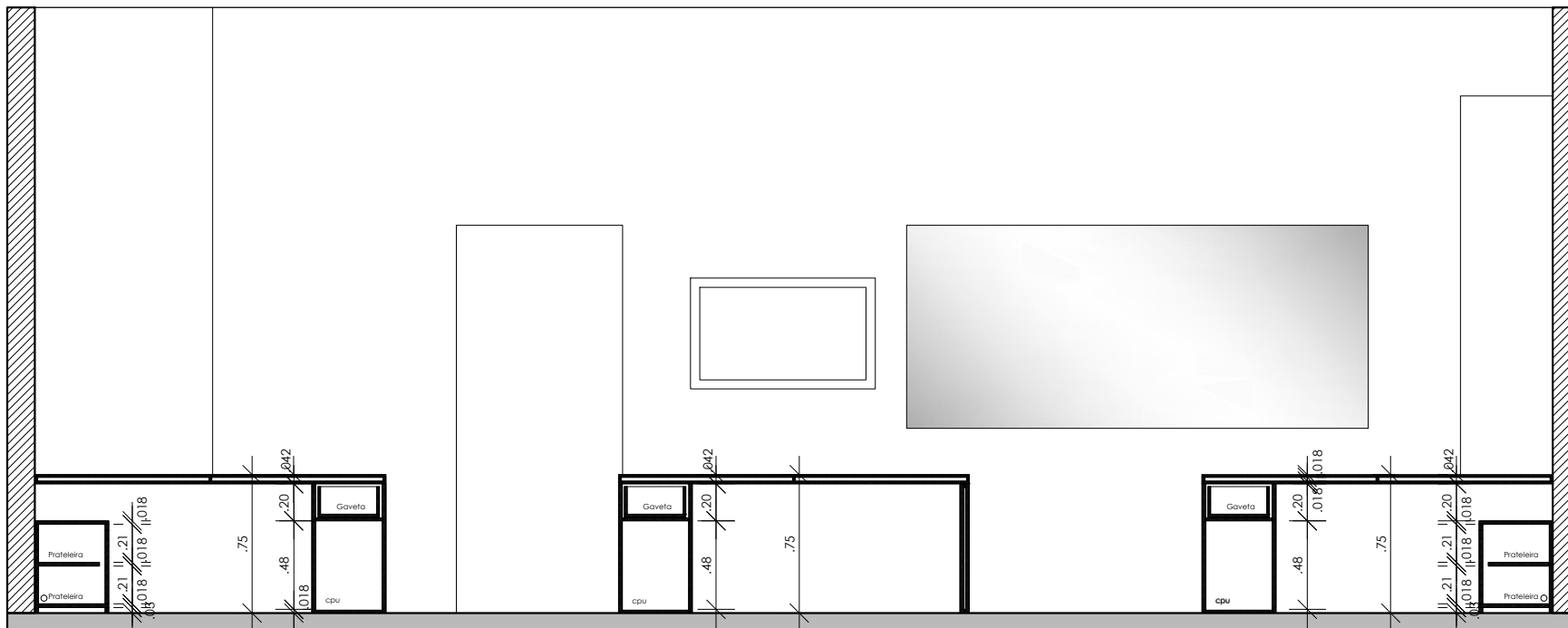

Corte CC Vista 03 - Sala da Tesouraria

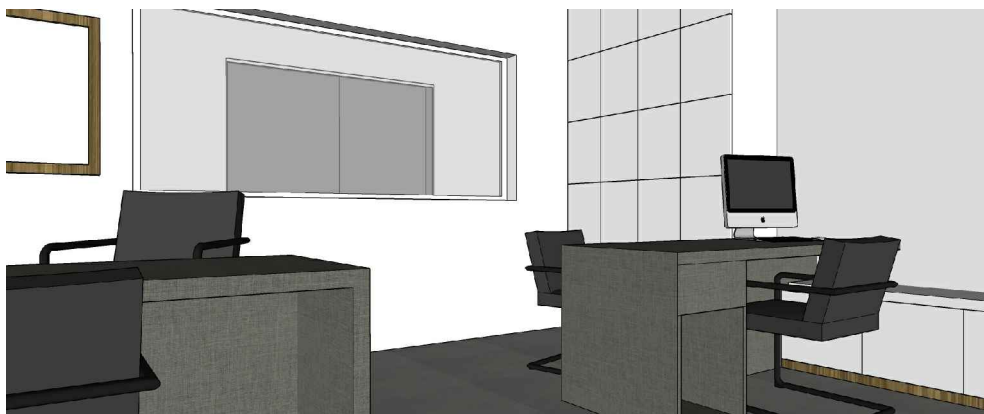

Projeto de Móveis - Câmara Municipal de Victor Graeff  
Sala da Tesouraria- 22

Arquiteta e Urbanista Tábora V. Petry  
CAU A64875-2

Fone: 054 99172-0565 - email: arche\_arche@outlook.com - Av. Família Barth - 07 - Victor Graeff - RS



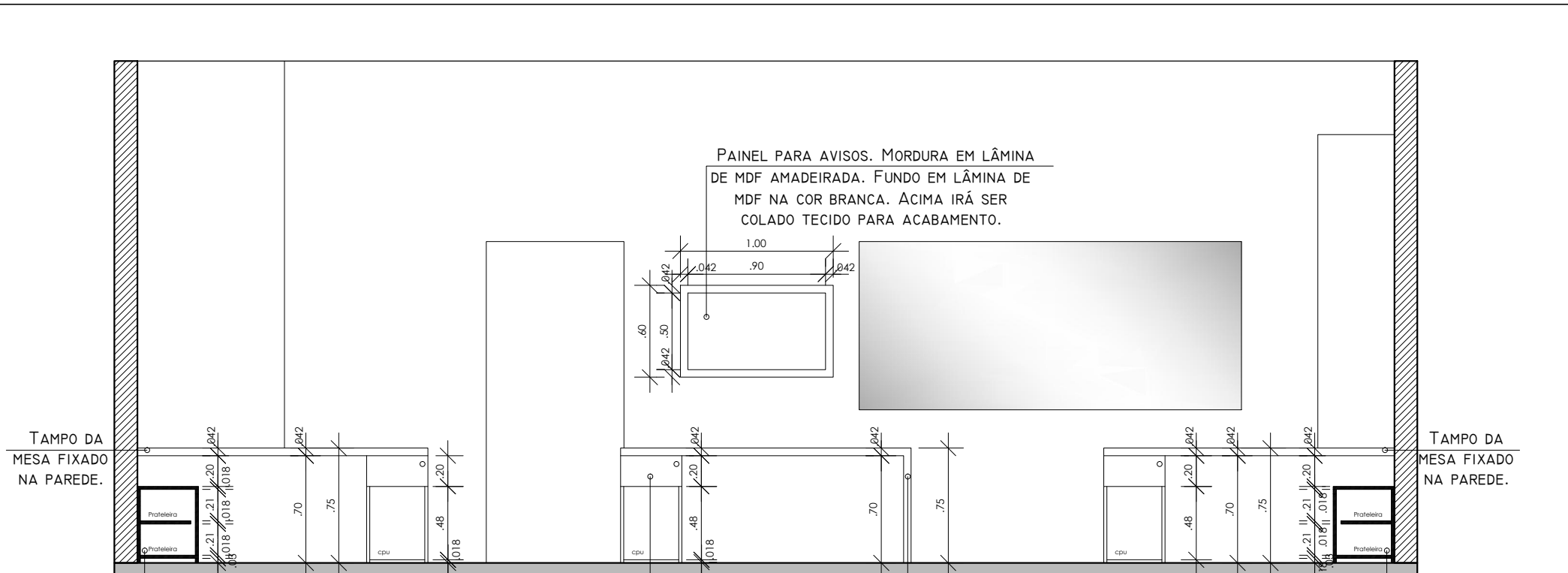

Vista 03 - Sala da Tesouraria

ARMÁRIO EM LÂMINA DE MDF NA COR BRANCA. RODAPÉ EM LÂMINA AMADEIRADA. AS PORTAS POSSUEM O SISTEMA DE ABERTURA DE CORRER.

ABERTURA DAS GAVETAS PELO SISTEMA CLICK. AS GAVETAS POSSUEM FECHAMENTO COM CHAVE. ABAIXO ESPAÇO PARA CPU.

MESAS EM LÂMINA DE MDF NA COR LINHO CINZA.

ARMÁRIO EM LÂMINA DE MDF NA COR BRANCA. RODAPÉ EM LÂMINA AMADEIRADA. AS PORTAS POSSUEM O SISTEMA DE ABERTURA DE CORRER.



Projeto de Móveis - Câmara Municipal de Victor Graeff  
Sala da Tesouraria- 23

Arquiteta e Urbanista Tábara V. Petry  
CAU A64875-2

Fone: 054 99172-0565 - email: arche\_arche@outlook.com - Av. Família Barth - 07 - Victor Graeff - RS



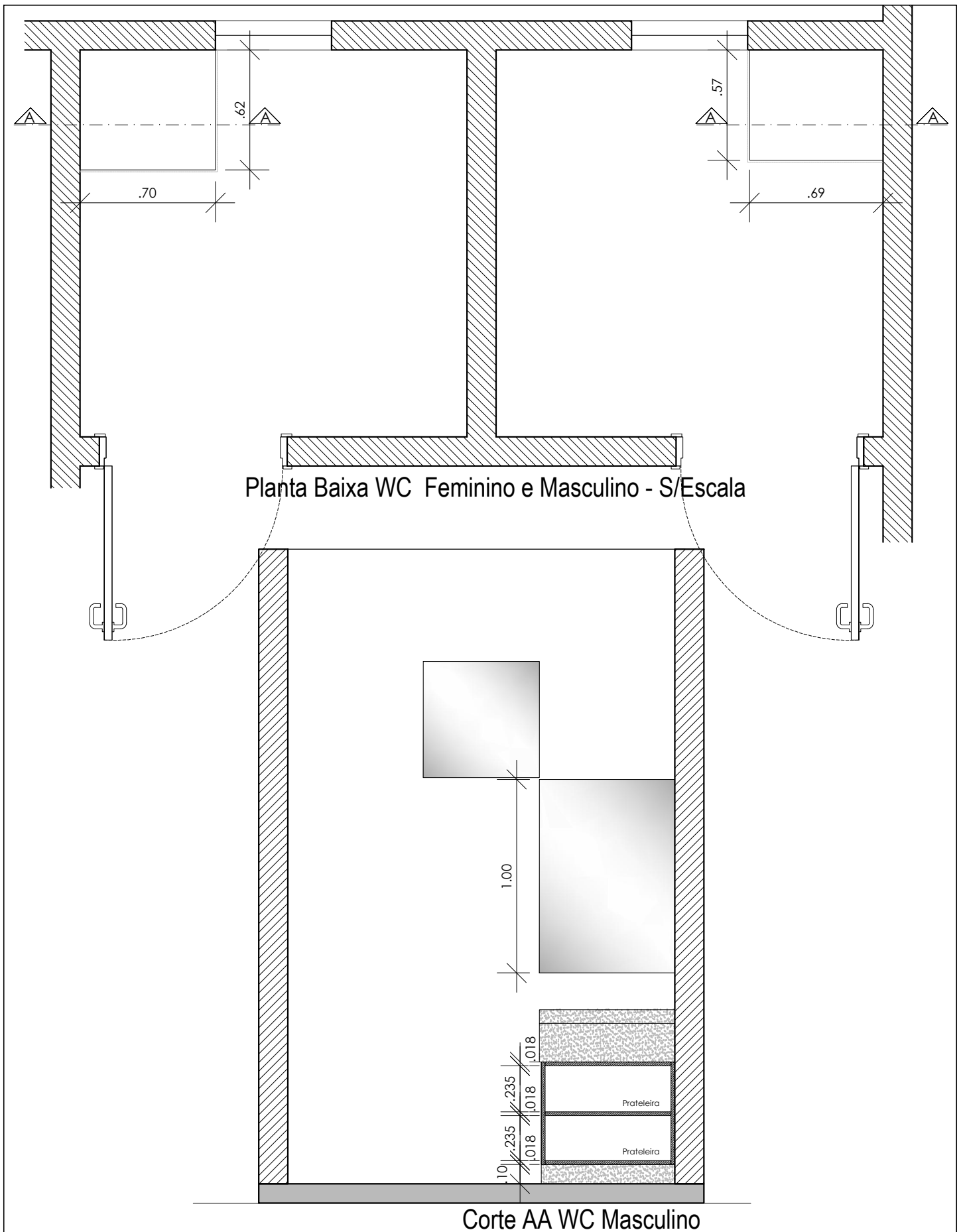

Projeto de Móveis - Câmara Municipal de Victor Graeff  
WC FEMININO E MASCULINO- 24

Arquiteta e Urbanista Tábara V. Petry  
CAU A64875-2

Fone: 054 99172-0565 - email: arche\_arche@outlook.com - Av. Família Barth - 07 - Victor Graeff - RS





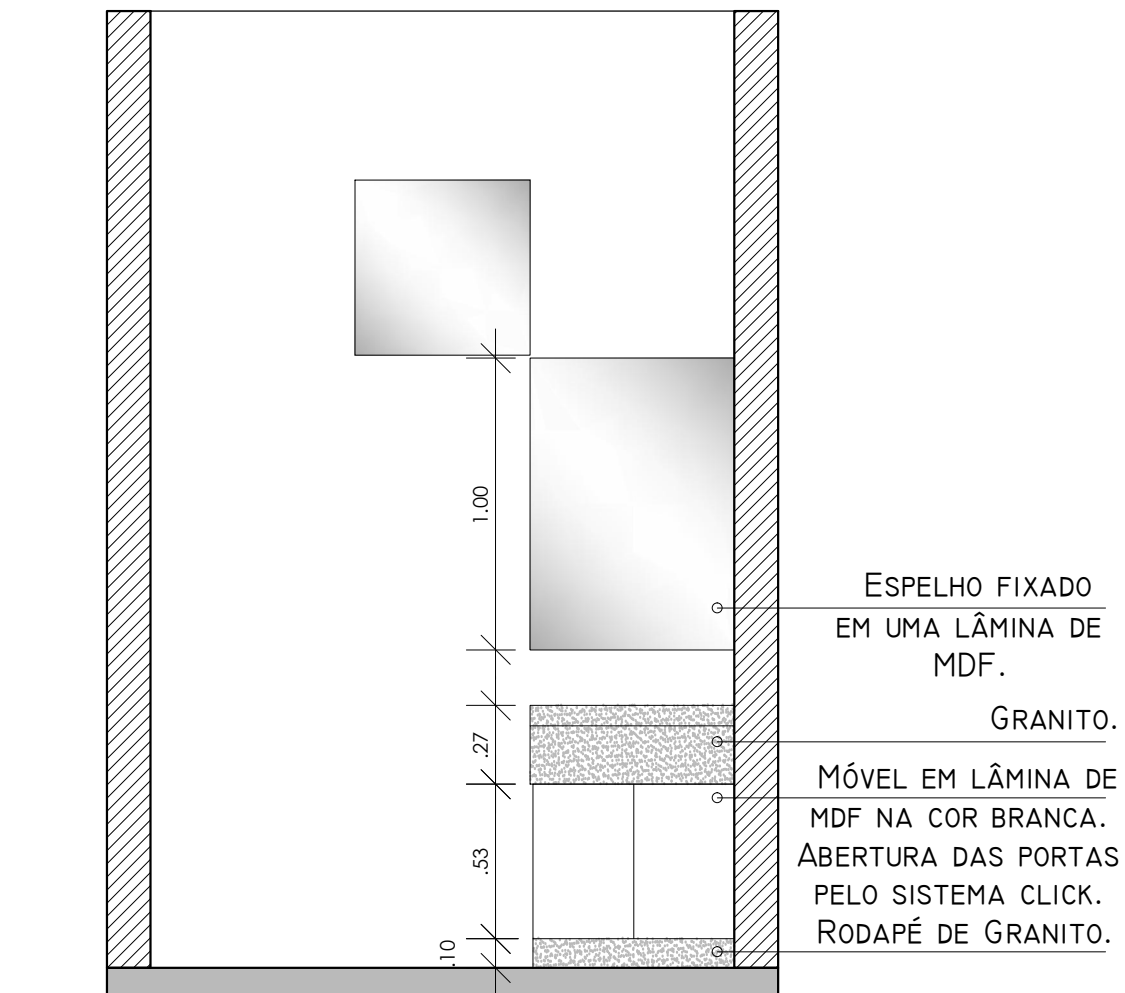

Vista WC Masculino

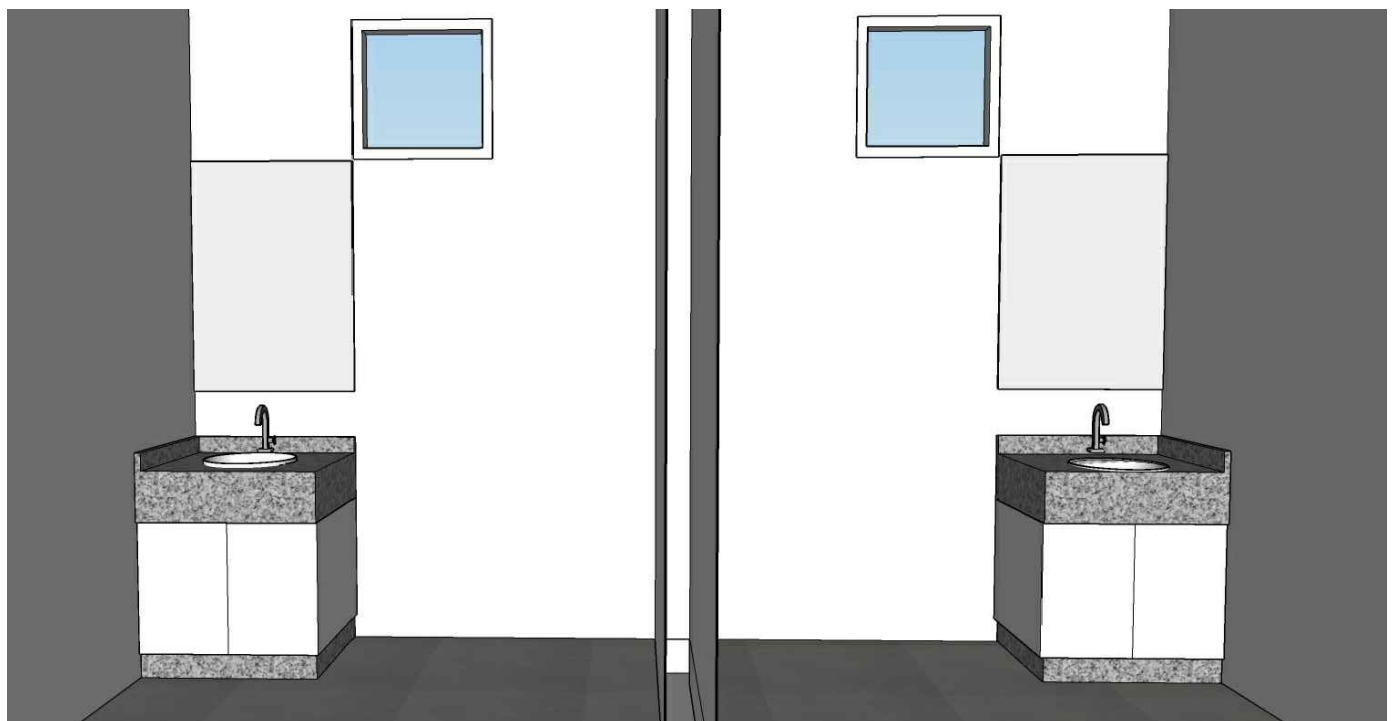

Projeto de Móveis - Câmara Municipal de Victor Graeff  
WC FEMININO E MASCULINO- 25

Arquiteta e Urbanista Tábara V. Petry  
CAU A64875-2

Fone: 054 99172-0565 - email: arche\_arche@outlook.com - Av. Família Barth - 07 - Victor Graeff - RS



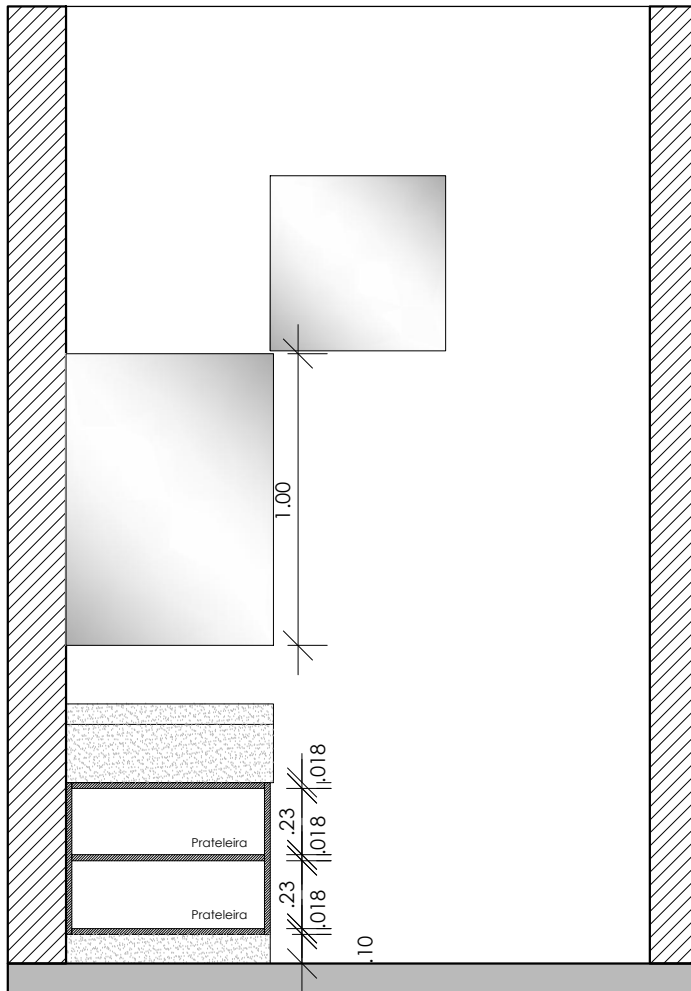

Corte AA WC Feminino

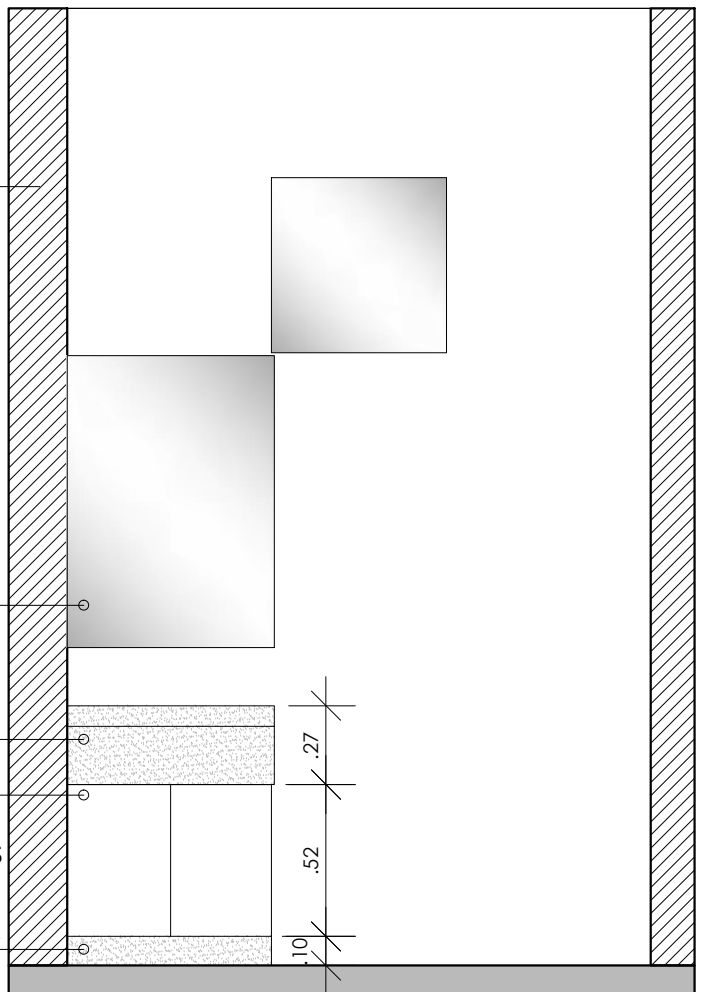

Vista WC Feminino

ESPELHO FIXADO  
EM UMA LÂMINA DE  
MDF.

GRANITO.

MÓVEL EM LÂMINA DE  
MDF NA COR BRANCA.  
ABERTURA DAS PORTAS  
PELO SISTEMA CLICK.  
RODAPÉ DE GRANITO.

Projeto de Móveis - Câmara Municipal de Victor Graeff  
WC FEMININO E MASCULINO- 26

Arquiteta e Urbanista Tábara V. Petry  
CAU A64875-2

Fone: 054 99172-0565 - email: arche\_arche@outlook.com - Av. Família Barth - 07 - Victor Graeff - RS



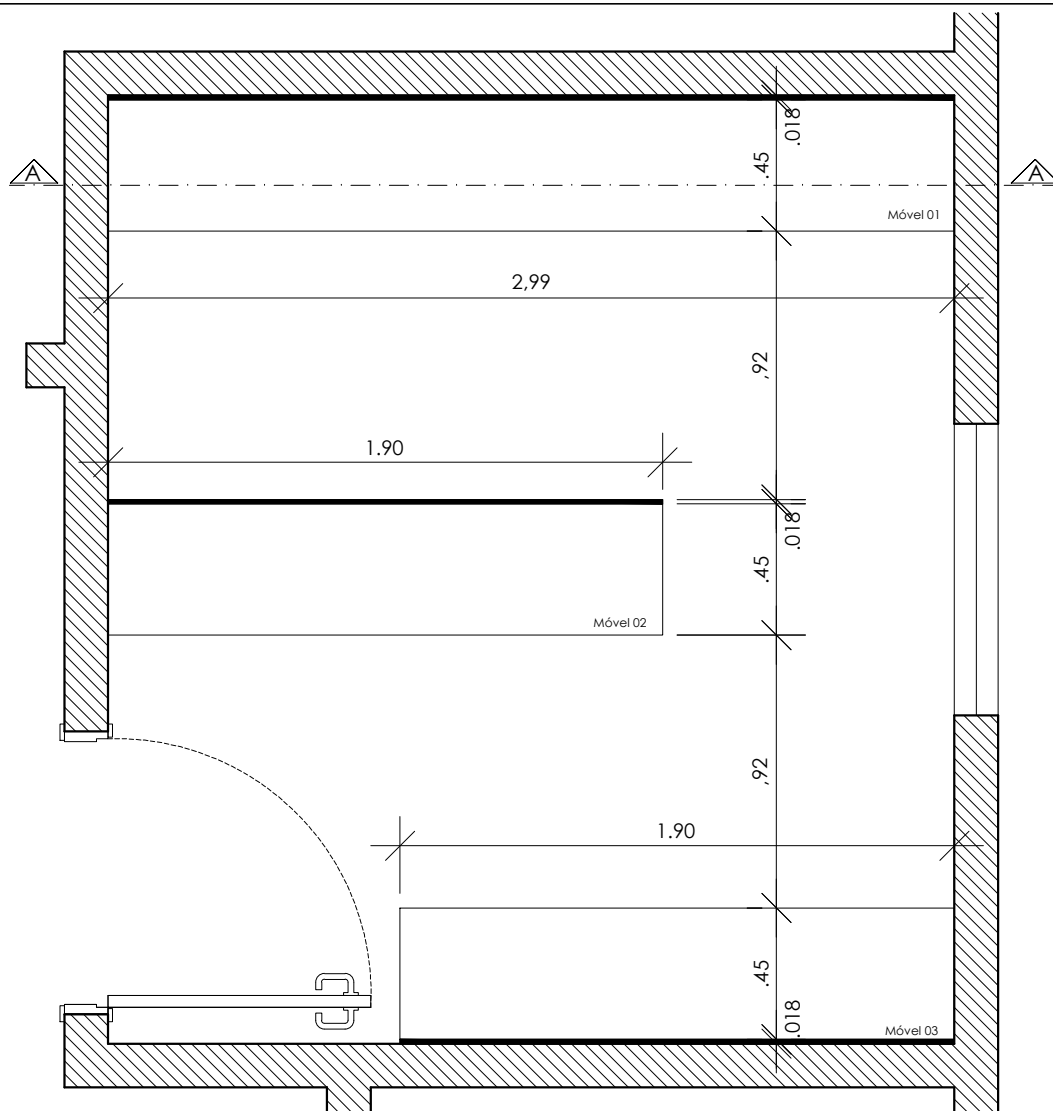

Planta Baixa Sala de Arquivo - S/Escala

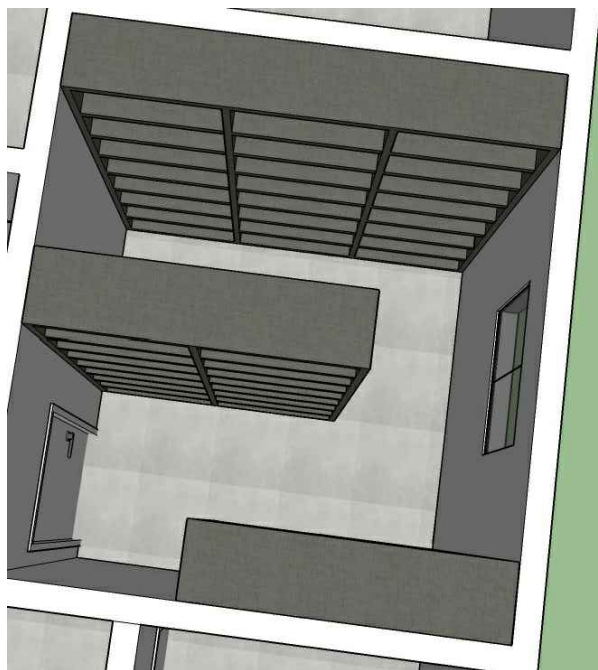

Projeto de Móveis - Câmara Municipal de Victor Graeff  
Sala de Arquivo- 27

Arquiteta e Urbanista Tábara V. Petry  
CAU A64875-2

Fone: 054 99172-0565 - email: arche\_arche@outlook.com - Av. Família Barth - 07 - Victor Graeff - RS



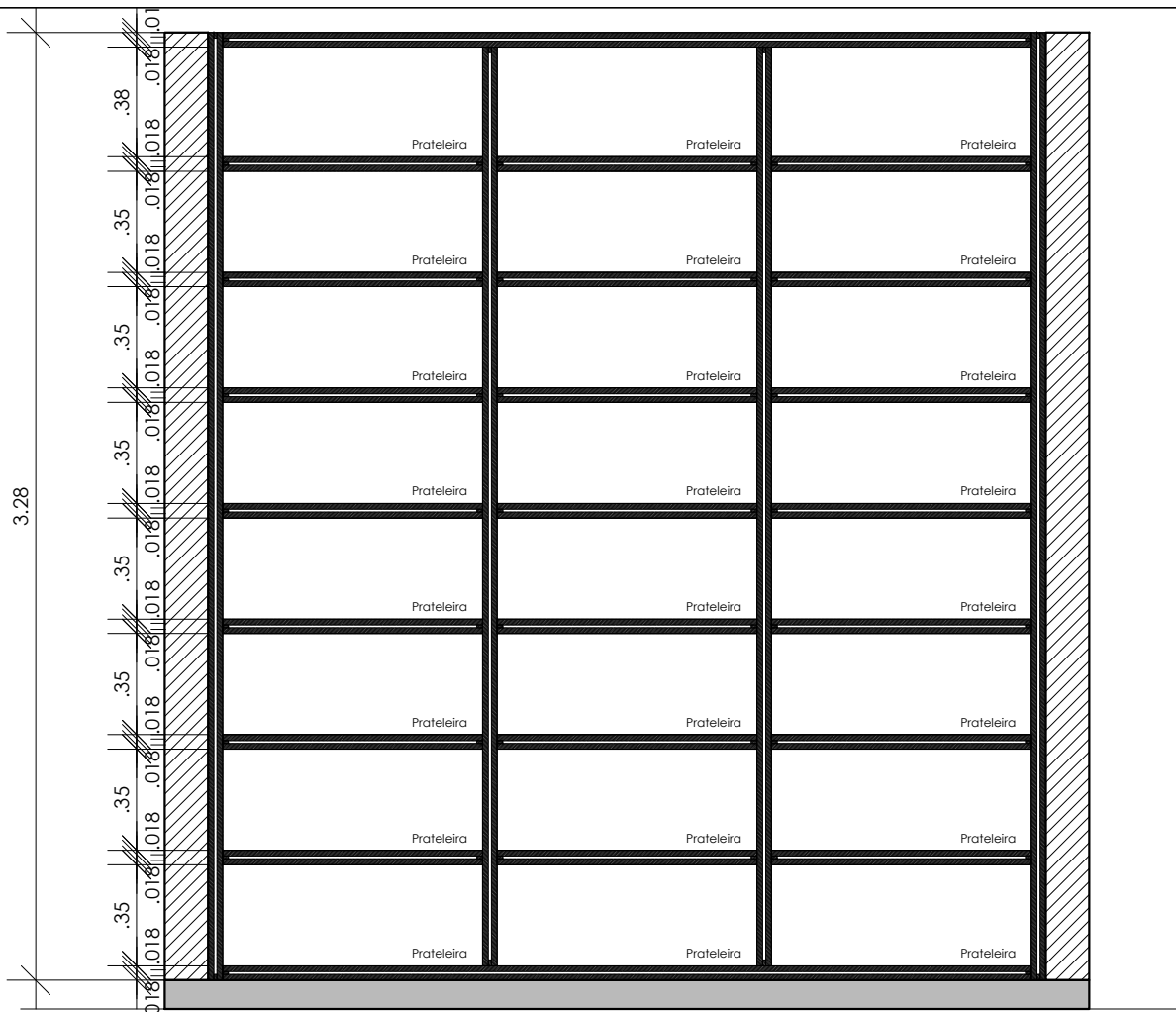

Corte AA Móvel 01- Sala de Arquivo

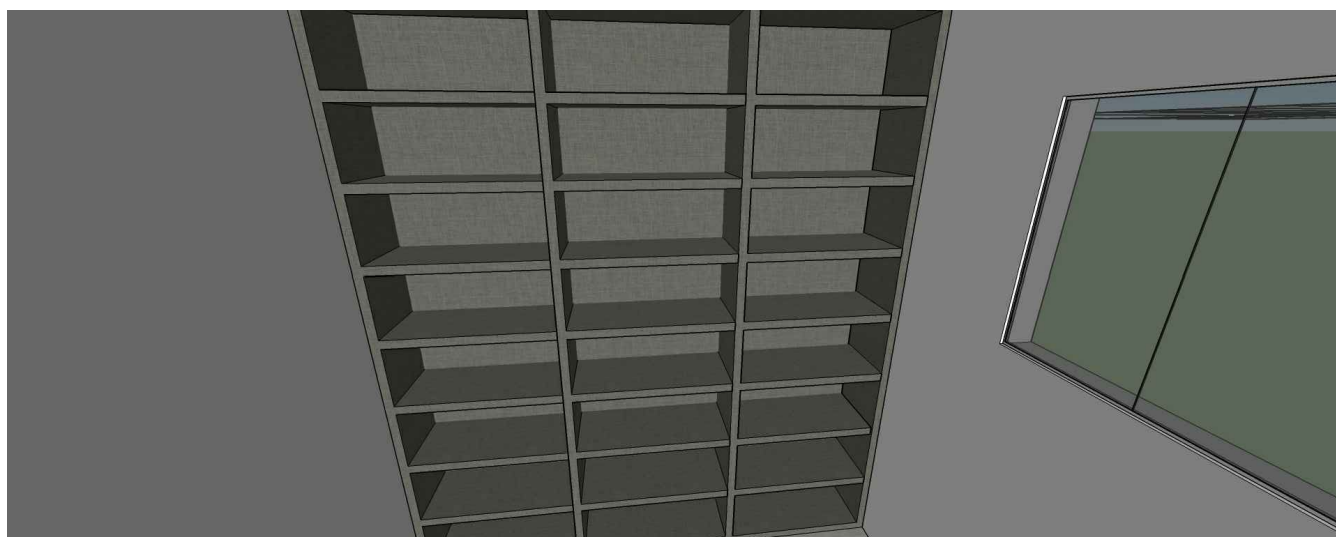

Projeto de Móveis - Câmara Municipal de Victor Graeff  
Sala de Arquivo- 28

Arquiteta e Urbanista Tábara V. Petry  
CAU A64875-2

Fone: 054 99172-0565 - email: arche\_arche@outlook.com - Av. Família Barth - 07 - Victor Graeff - RS









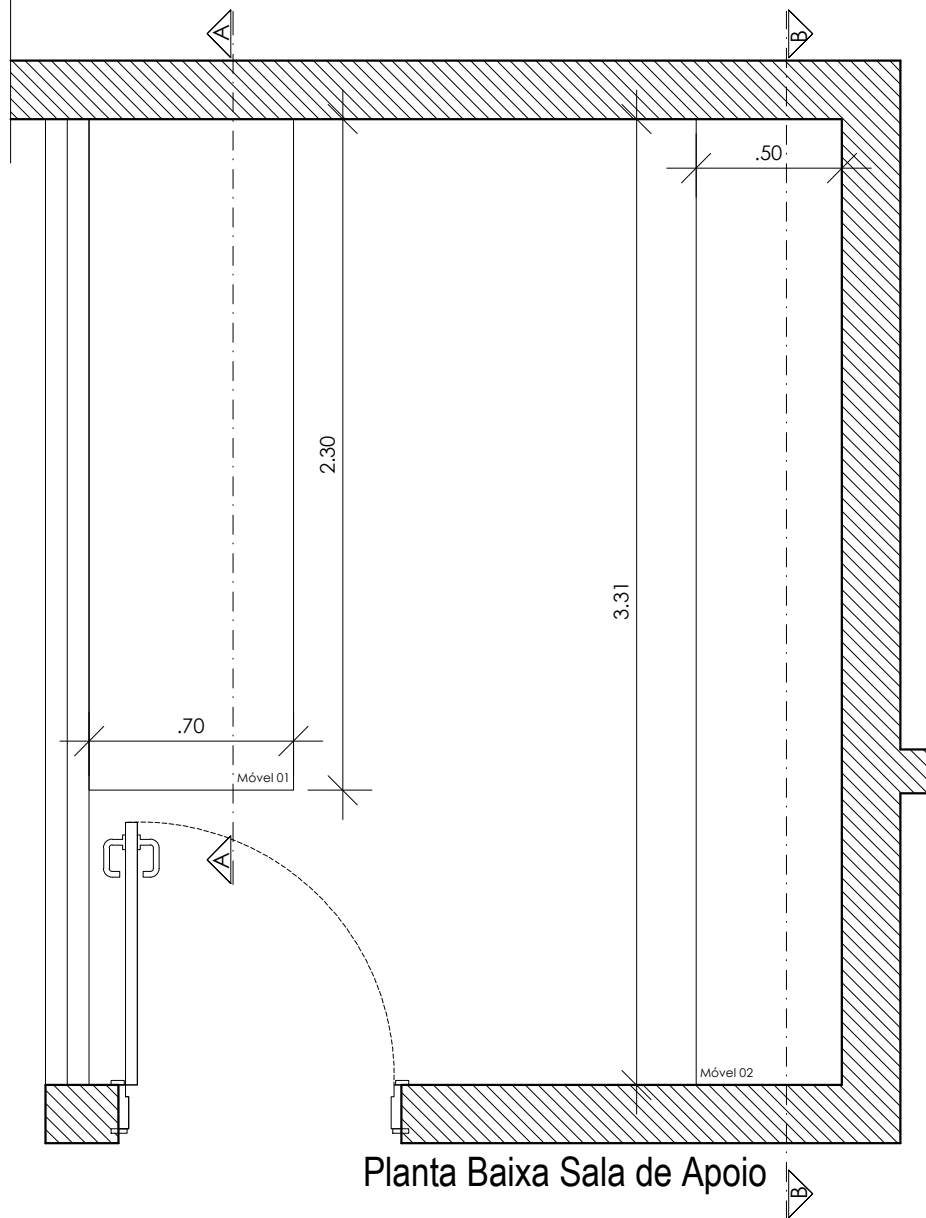

Projeto de Móveis - Câmara Municipal de Victor Graeff  
Sala de Apoio- 32

Arquiteta e Urbanista Tábara V. Petry  
CAU A64875-2

Fone: 054 99172-0565 - email: arche\_arche@outlook.com - Av. Família Barth - 07 - Victor Graeff - RS





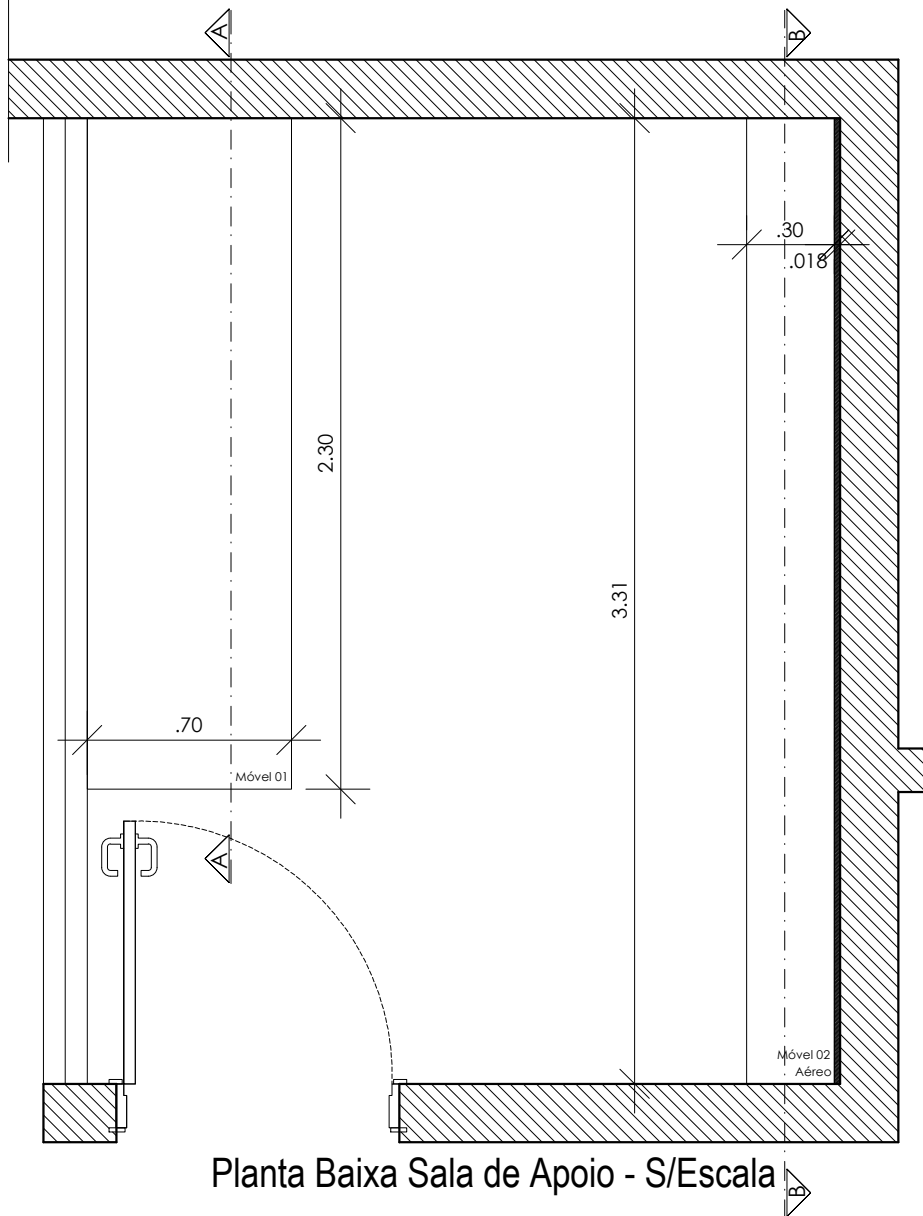

Planta Baixa Sala de Apoio - S/Escala

Projeto de Móveis - Câmara Municipal de Victor Graeff  
Sala de Apoio- 33

Arquiteta e Urbanista Tábara V. Petry  
CAU A64875-2

Fone: 054 99172-0565 - email: arche\_arche@outlook.com - Av. Família Barth - 07 - Victor Graeff - RS



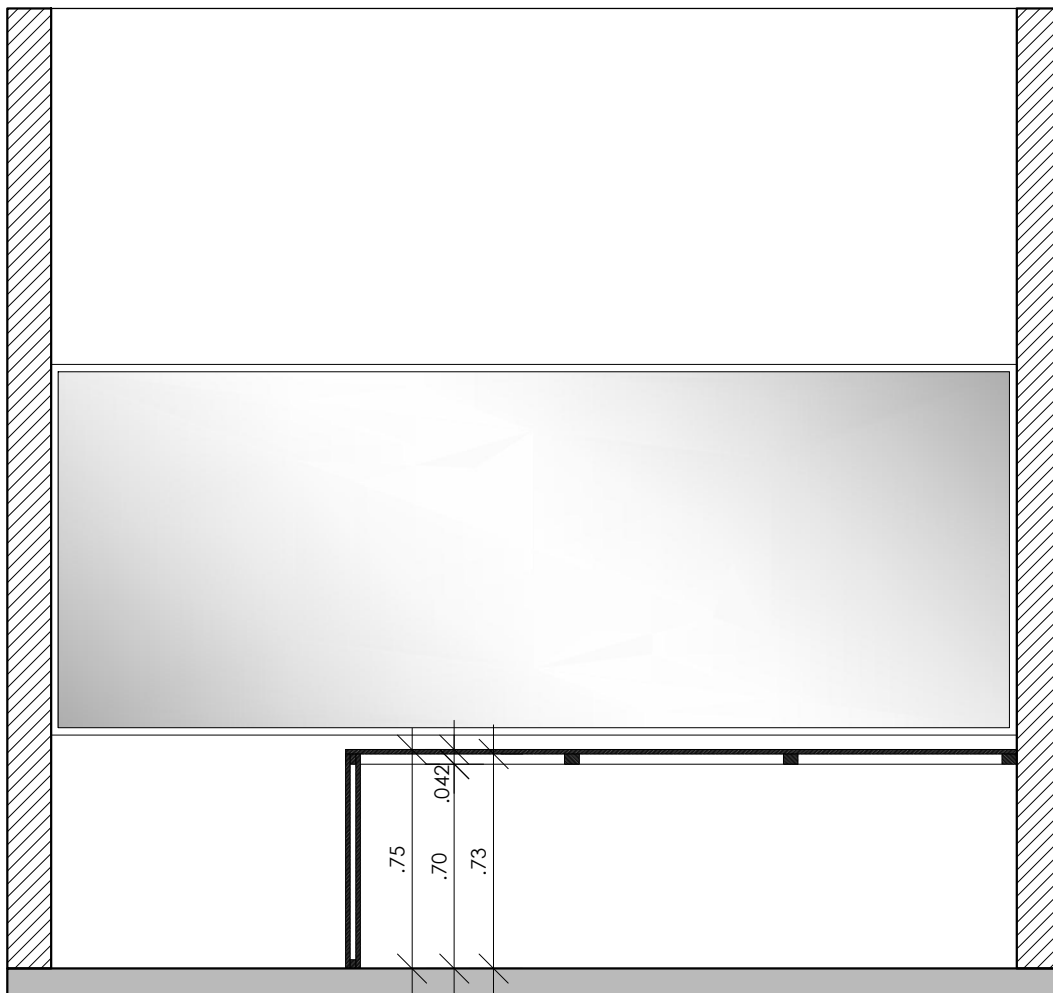

Corte AA Móvel 01 - Sala de Apoio

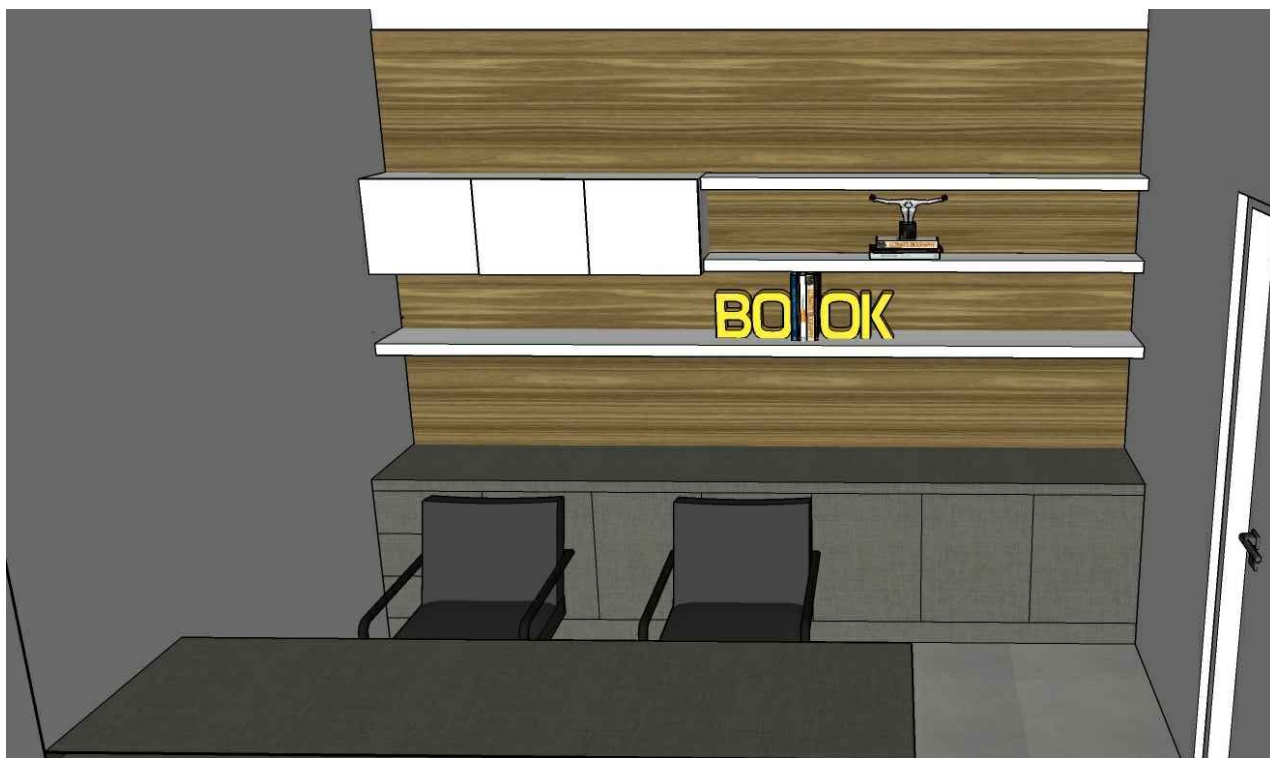

Projeto de Móveis - Câmara Municipal de Victor Graeff  
Sala de Apoio- 34

Arquiteta e Urbanista Tábara V. Petry  
CAU A64875-2

Fone: 054 99172-0565 - email: arche\_arche@outlook.com - Av. Família Barth - 07 - Victor Graeff - RS



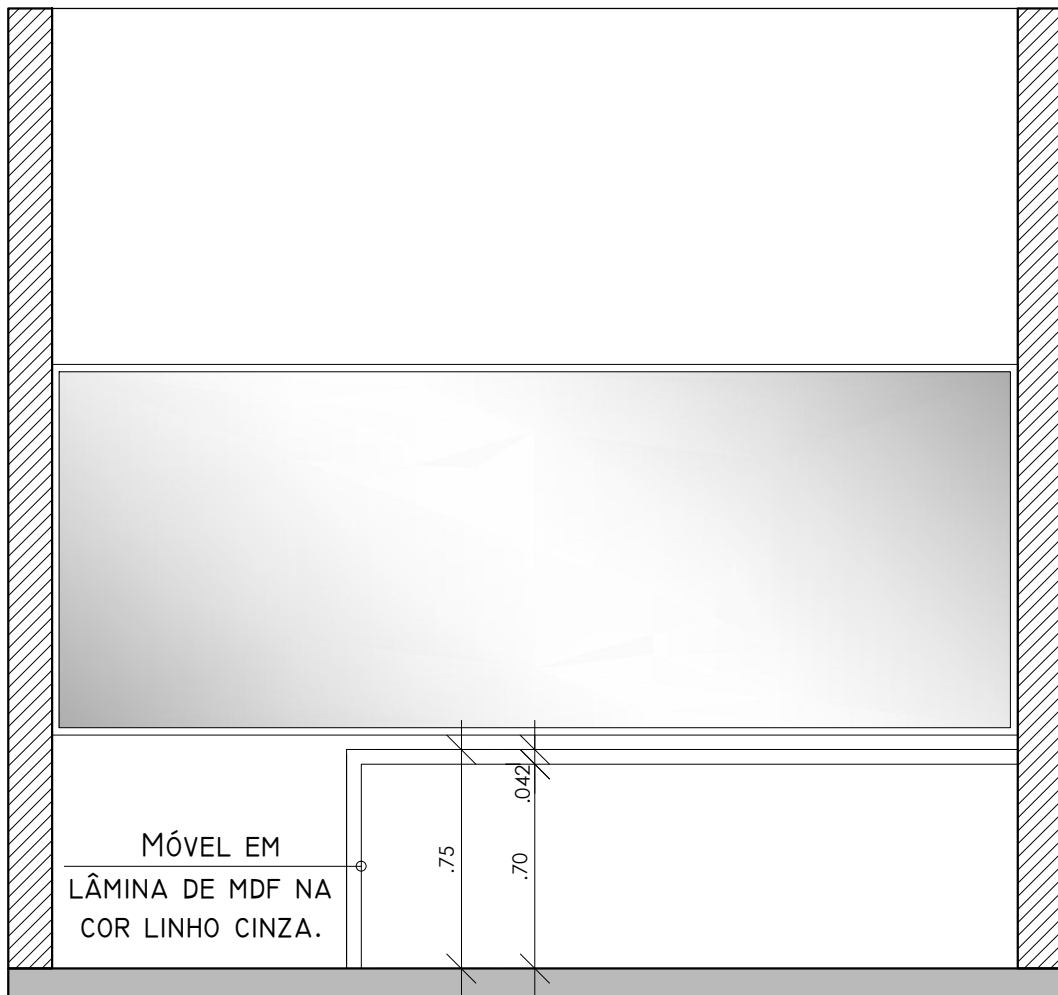

Vista Móvel 01 - Sala de Apoio



Projeto de Móveis - Câmara Municipal de Victor Graeff  
Sala de Apoio- 35

Arquiteta e Urbanista Tábara V. Petry  
CAU A64875-2

Fone: 054 99172-0565 - email: arche\_arche@outlook.com - Av. Família Barth - 07 - Victor Graeff - RS



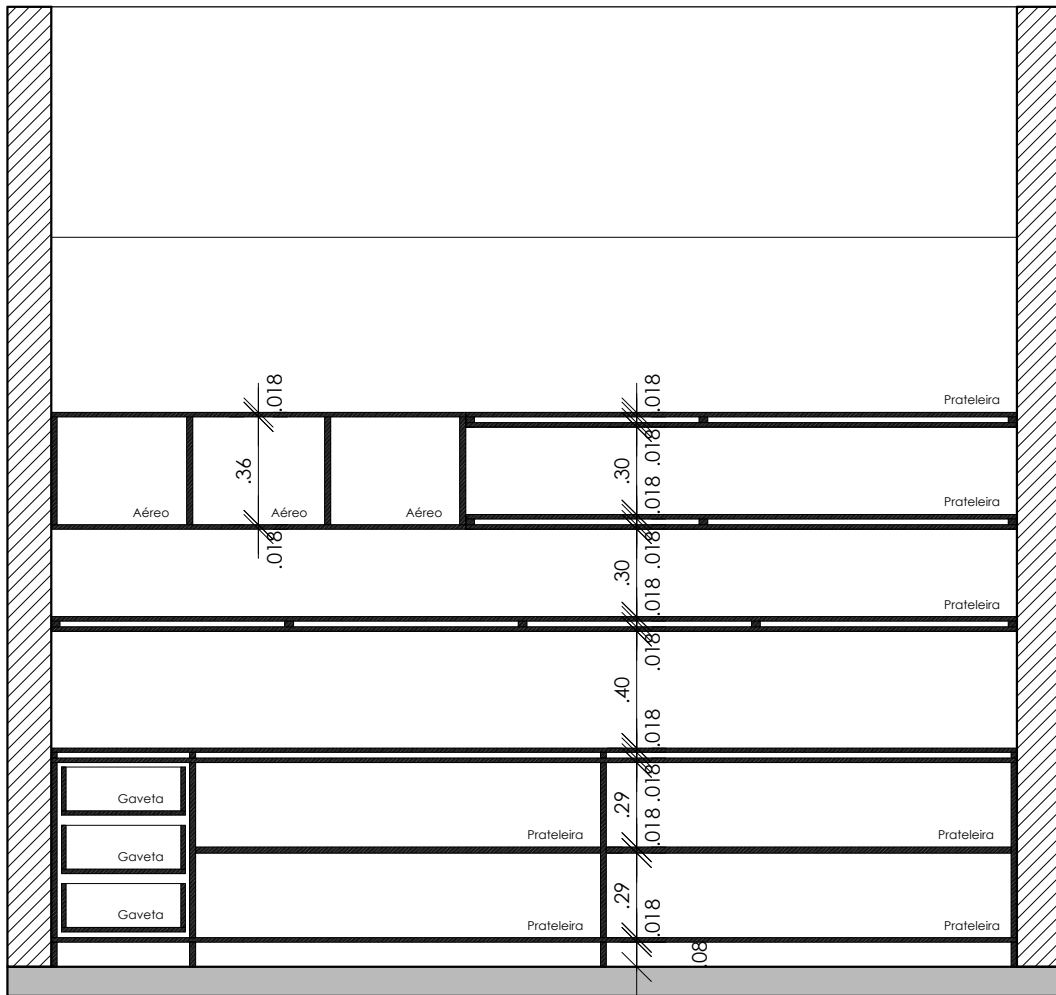

Corte BB Móvel 02 - Sala de Apoio



Projeto de Móveis - Câmara Municipal de Victor Graeff  
Sala de Apoio- 36

Arquiteta e Urbanista Tábara V. Petry  
CAU A64875-2

Fone: 054 99172-0565 - email: arche\_arche@outlook.com - Av. Família Barth - 07 - Victor Graeff - RS



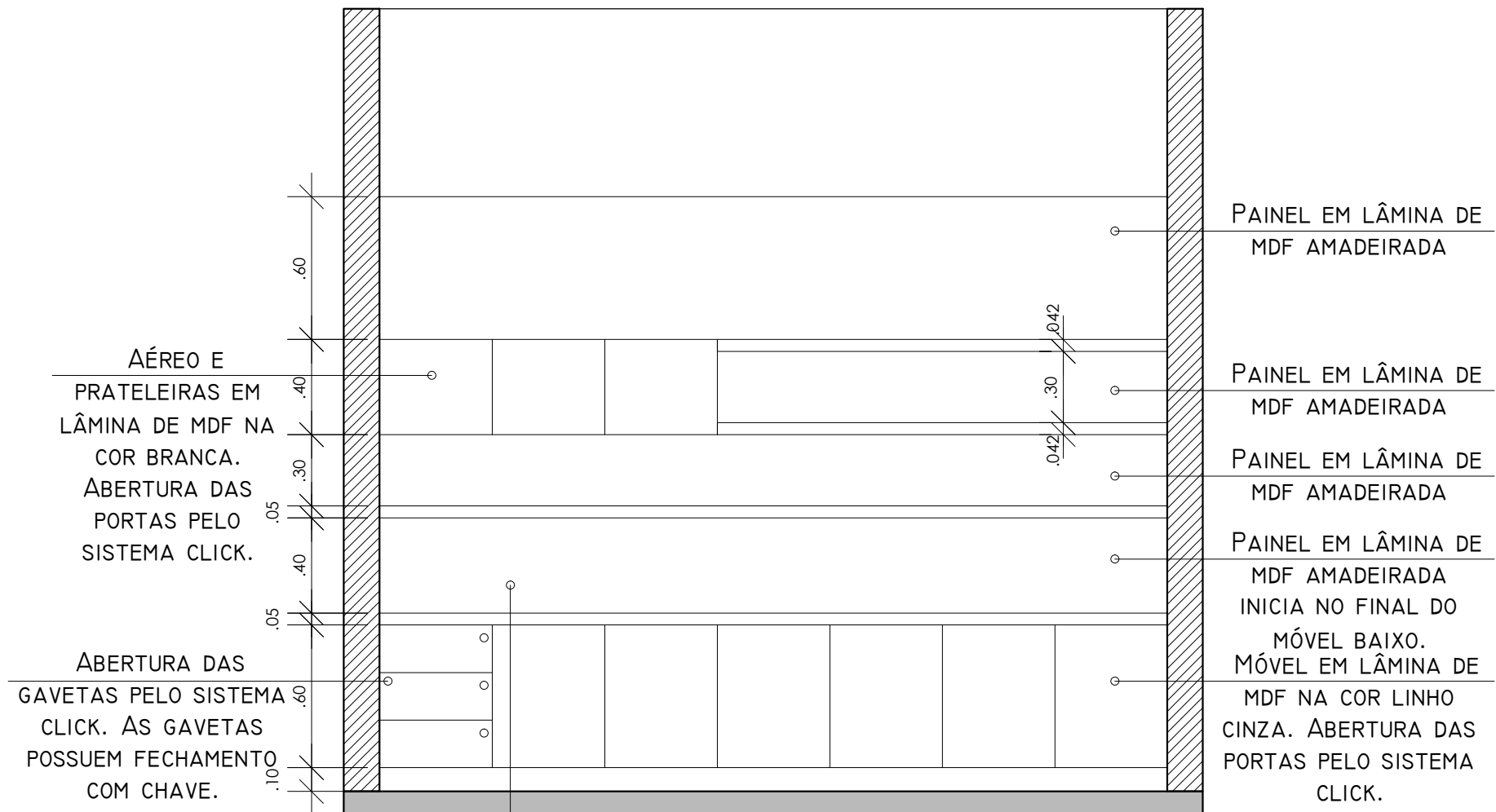

Vista Móvel 02 - Sala de Apoio

DESLOCAR AS TOMADAS PARA O PAINEL ACIMA DO MÓVEL. (DEFINIR A LOCALIZAÇÃO COM O CLIENTE)

Projeto de Móveis - Câmara Municipal de Victor Graeff  
 Sala da Tesouraria- 37

Arquiteta e Urbanista Tábora V. Petry  
 CAU A64875-2

Fone: 054 99172-0565 - email: arche\_arche@outlook.com - Av. Família Barth - 07 - Victor Graeff - RS



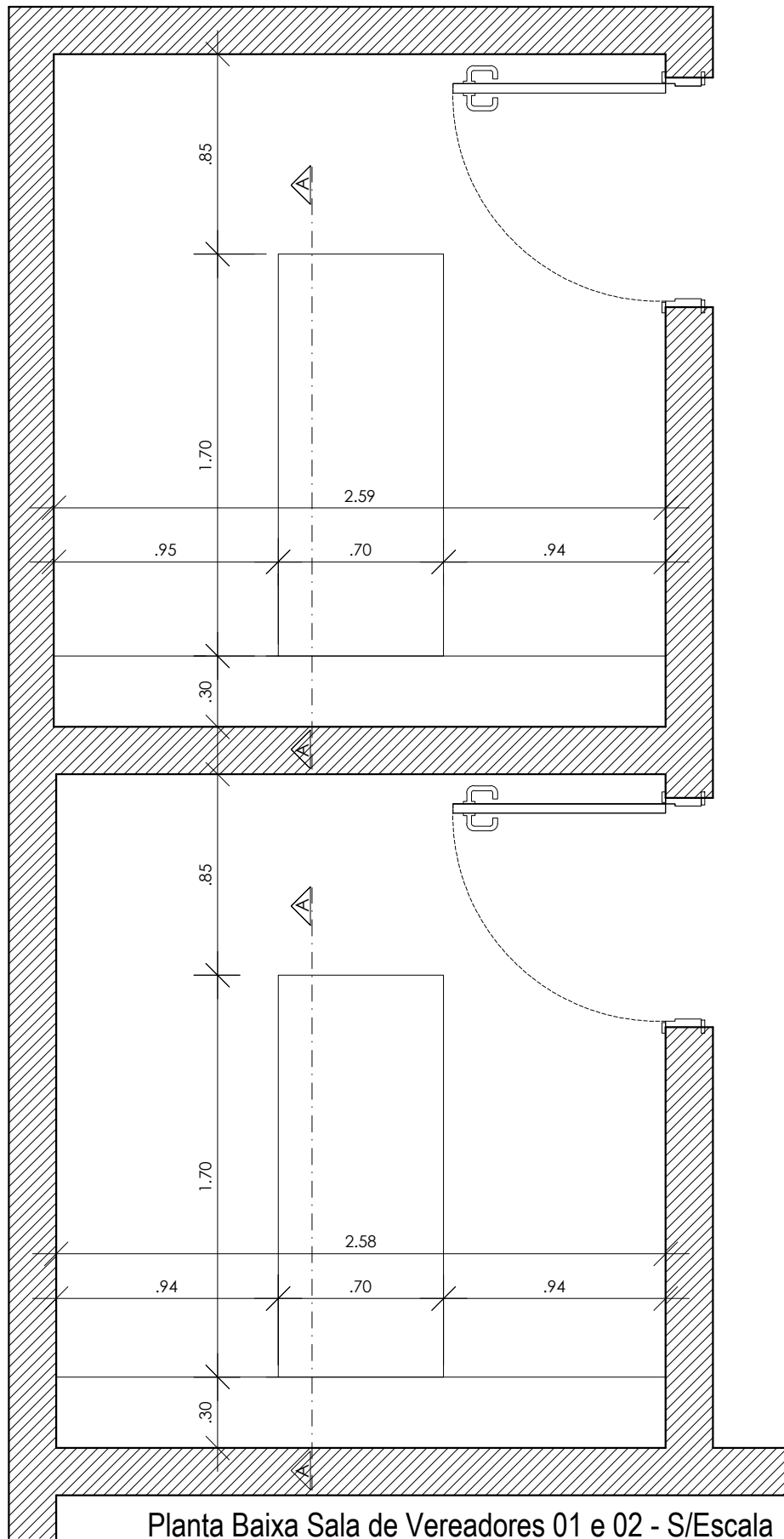

Planta Baixa Sala de Vereadores 01 e 02 - S/Escala

Projeto de Móveis - Câmara Municipal de Victor Graeff  
Sala de Vereadores 01 e 02- 38

Arquiteta e Urbanista Tábara V. Petry  
CAU A64875-2

Fone: 054 99172-0565 - email: arche\_arche@outlook.com - Av. Família Barth - 07 - Victor Graeff - RS



ABERTURA PARA  
ENTRADA DE  
DOCUMENTAÇÃO.  
PORTA BASCULANTE  
COM SISTEMA CLICK  
PARA ABERTURA.  
ESPAÇO DE 3CM  
DEIXADO ATRÁS DO  
PAINEL PARA FIAÇÃO.

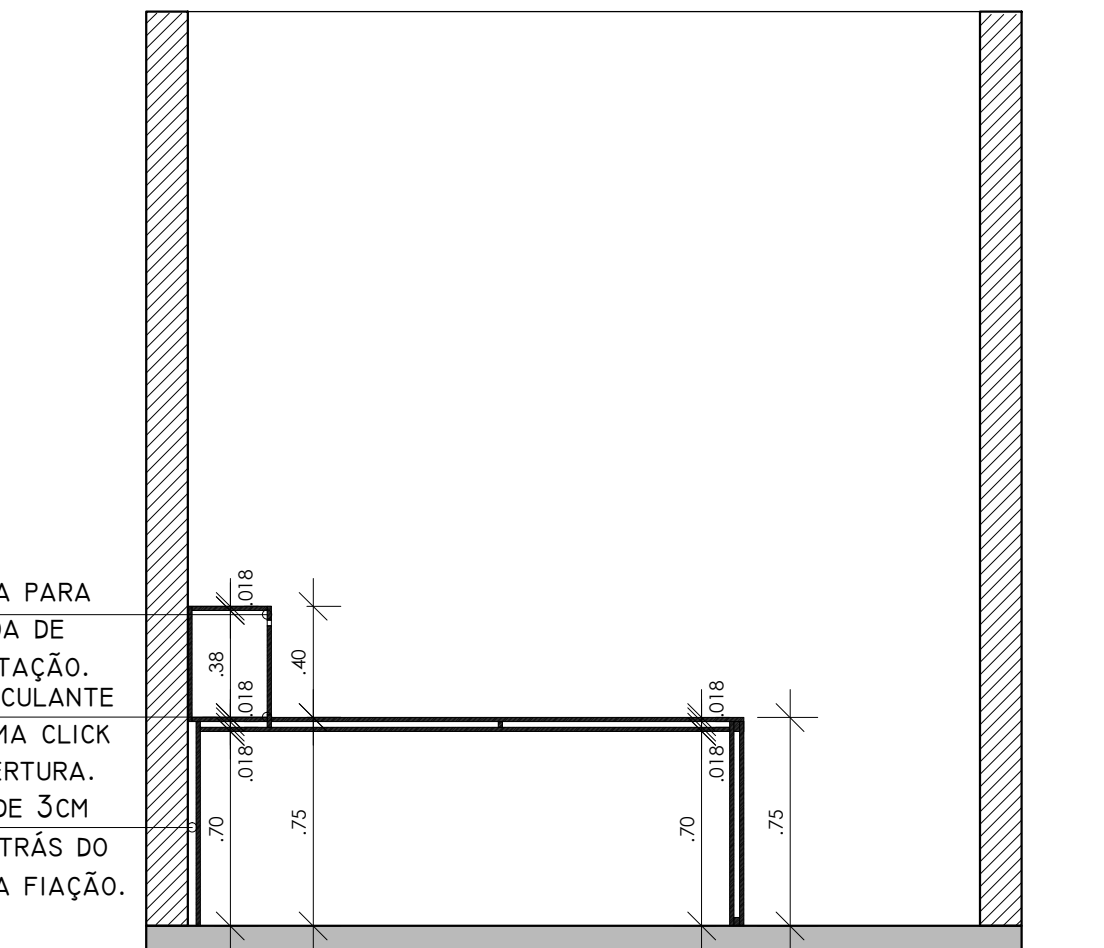

Corte AA Sala de Vereadores 01 e 02

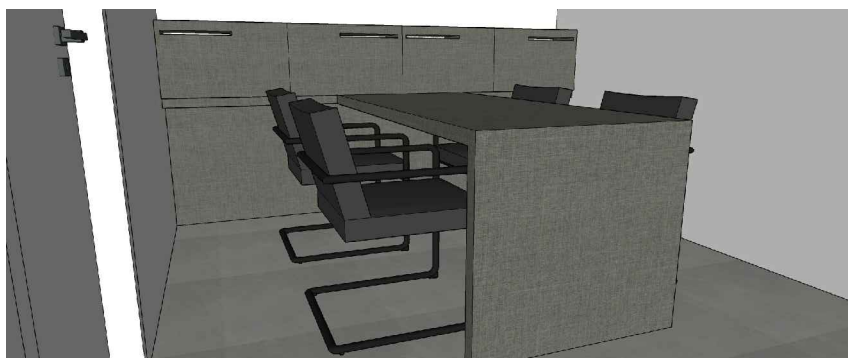
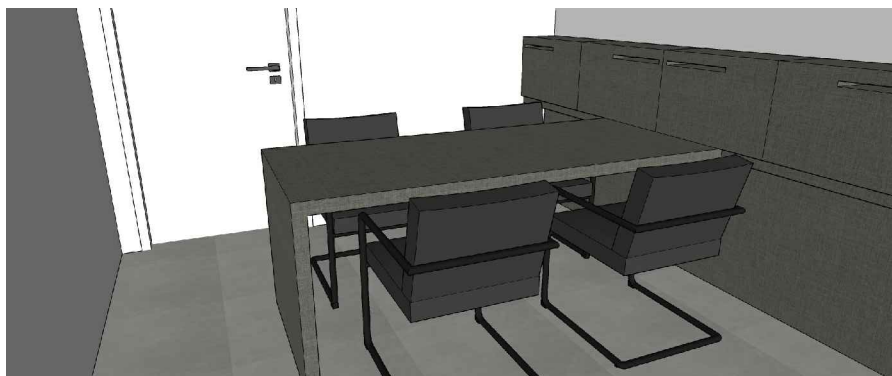

Projeto de Móveis - Câmara Municipal de Victor Graeff  
Sala de Vereadores 01 e 02- 39

Arquiteta e Urbanista Tábara V. Petry  
CAU A64875-2

Fone: 054 99172-0565 - email: arche\_arche@outlook.com - Av. Família Barth - 07 - Victor Graeff - RS



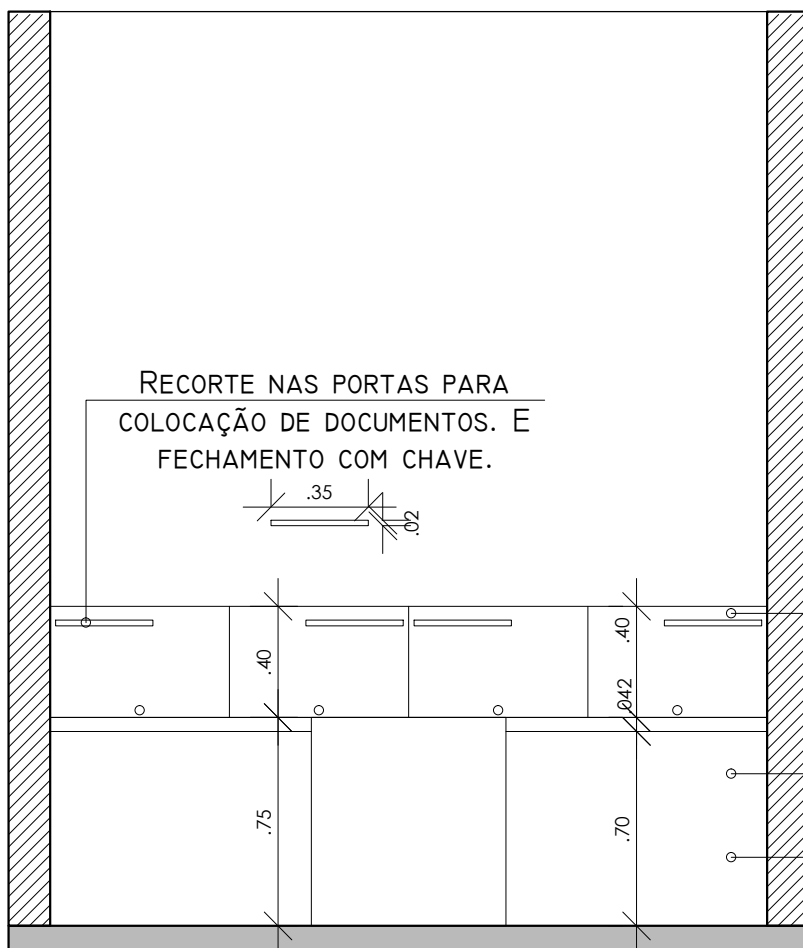

MÓVEL EM LÂMINA DE MDF NA COR LINHO CINZA. PORTAS BASCULANTES COM ABERTURA PELO SISTEMA CLICK.

PAINEL EM LÂMINA DE MDF NA COR LINHO CINZA.

DESLOCAR AS TOMADAS PARA O PAINEL ABAIXO DO MÓVEL. (DEFINIR A LOCALIZAÇÃO COM O CLIENTE)

Vista Sala de Vereadores 01 e 02



Projeto de Móveis - Câmara Municipal de Victor Graeff  
Sala de Vereadores 01 e 02- 40

Arquiteta e Urbanista Tábara V. Petry  
CAU A64875-2

Fone: 054 99172-0565 - email: arche\_arche@outlook.com - Av. Família Barth - 07 - Victor Graeff - RS





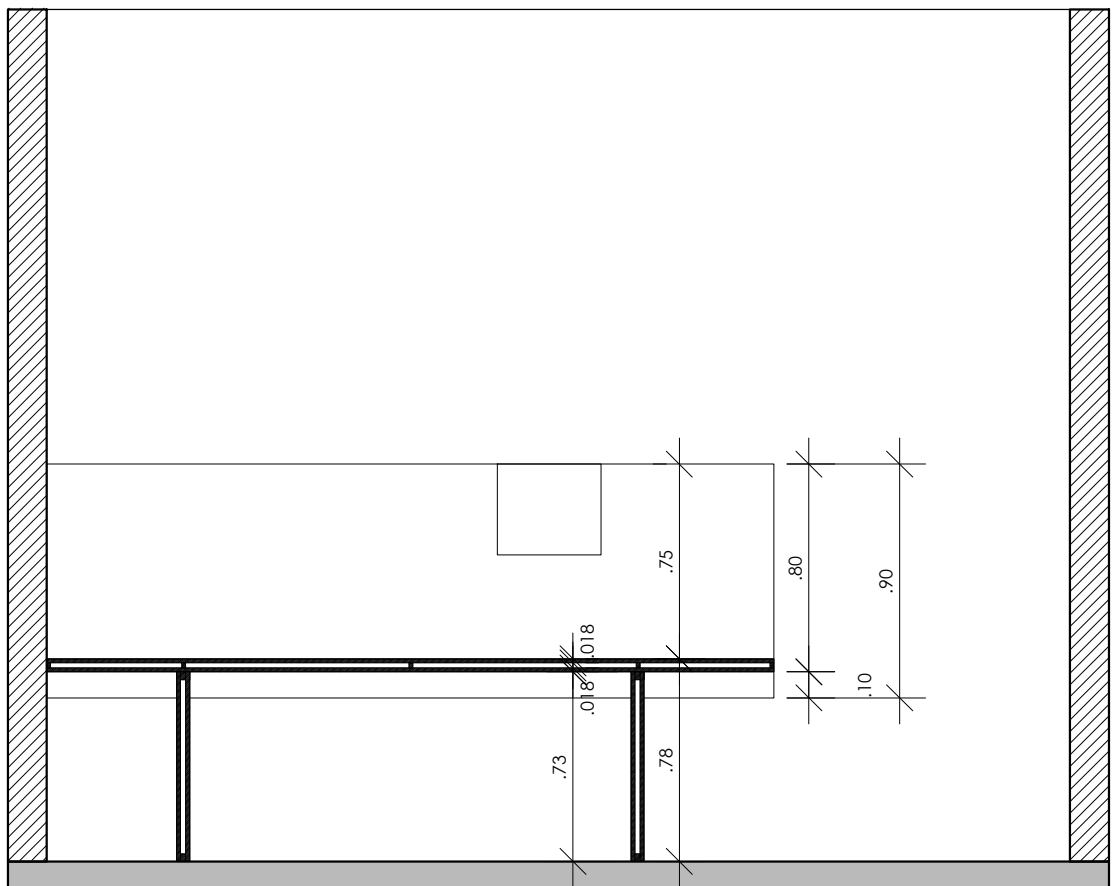
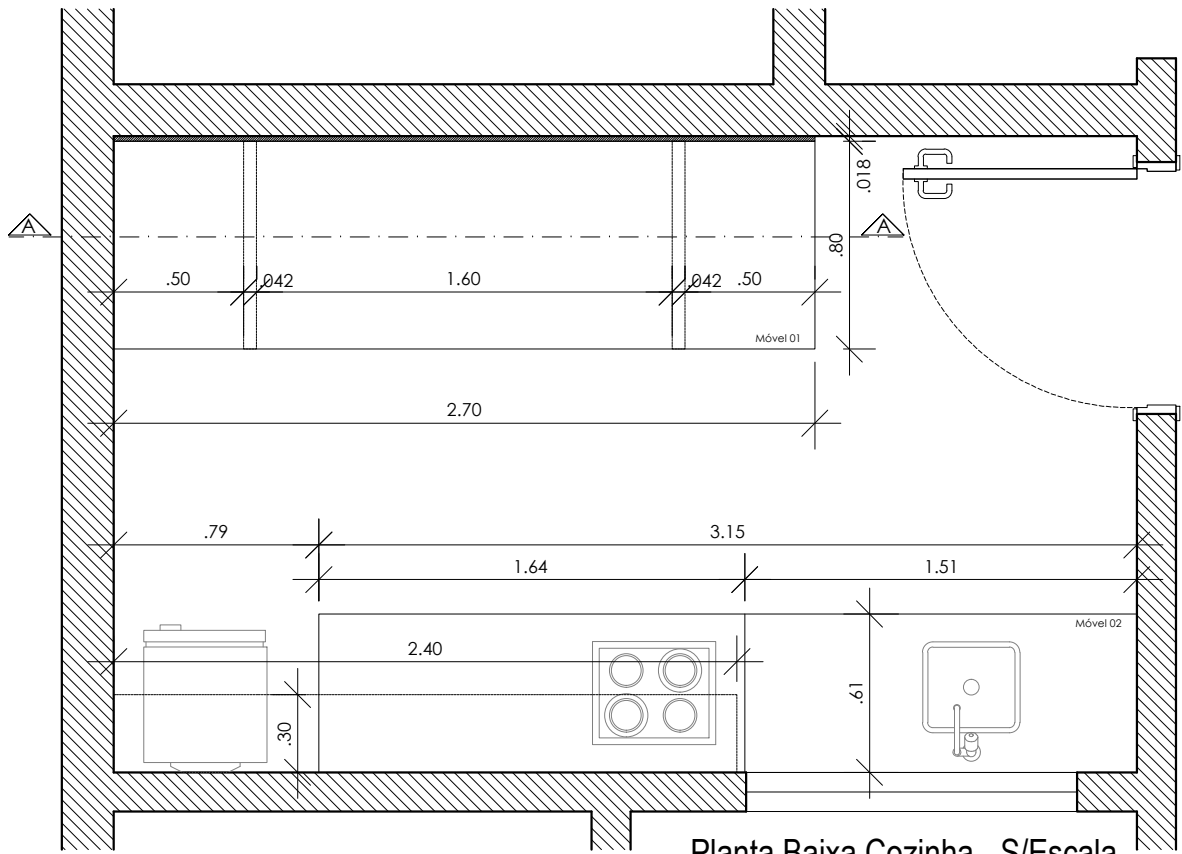

Projeto de Móveis - Câmara Municipal de Victor Graeff  
Cozinha- 41

Arquiteta e Urbanista Tábara V. Petry  
CAU A64875-2

Fone: 054 99172-0565 - email: arche\_arche@outlook.com - Av. Família Barth - 07 - Victor Graeff - RS



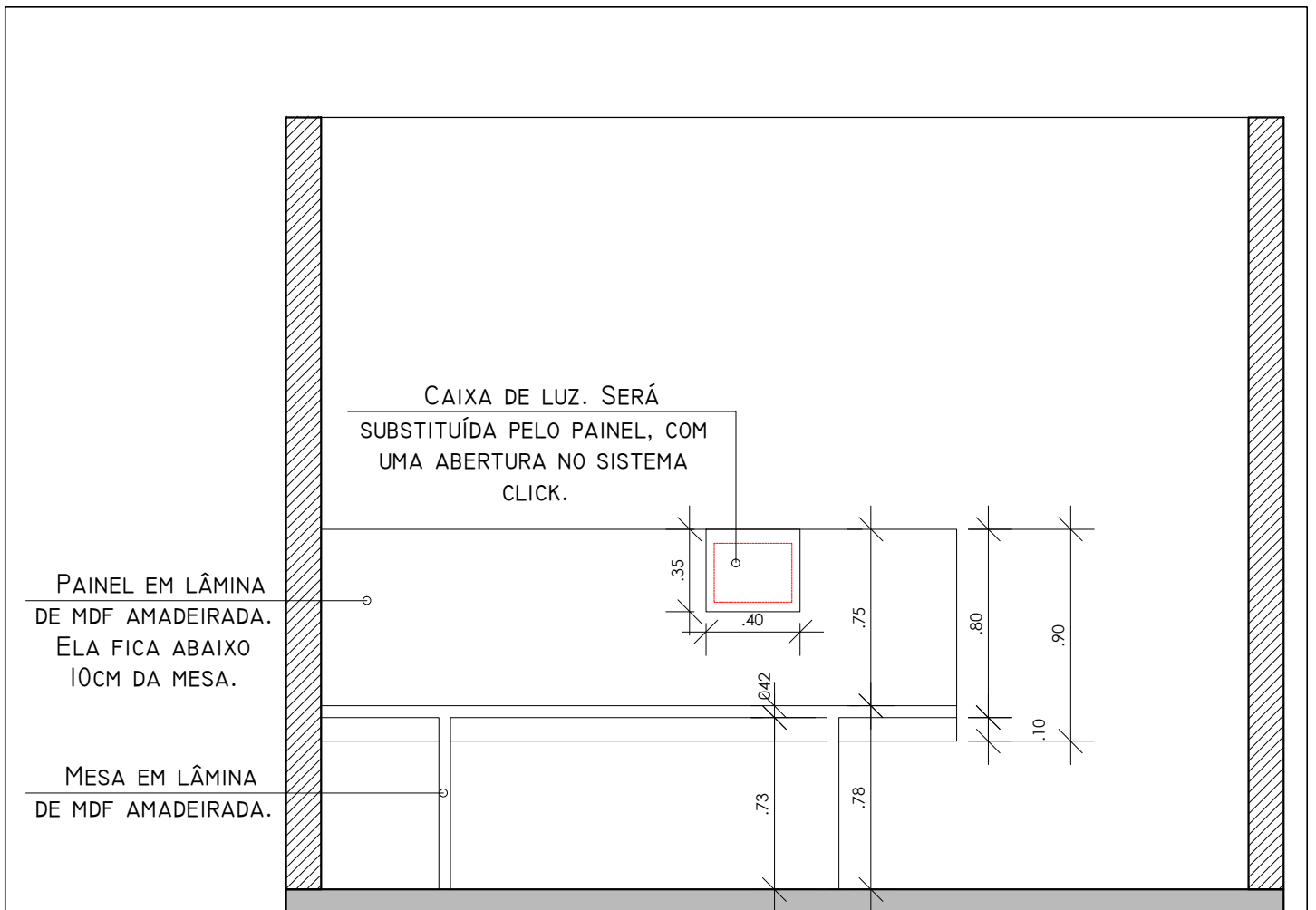

Vista Móvel 01 - cozinha



Projeto de Móveis - Câmara Municipal de Victor Graeff  
Cozinha- 42

Arquiteta e Urbanista Tábara V. Petry  
CAU A64875-2

Fone: 054 99172-0565 - email: arche\_arche@outlook.com - Av. Família Barth - 07 - Victor Graeff - RS





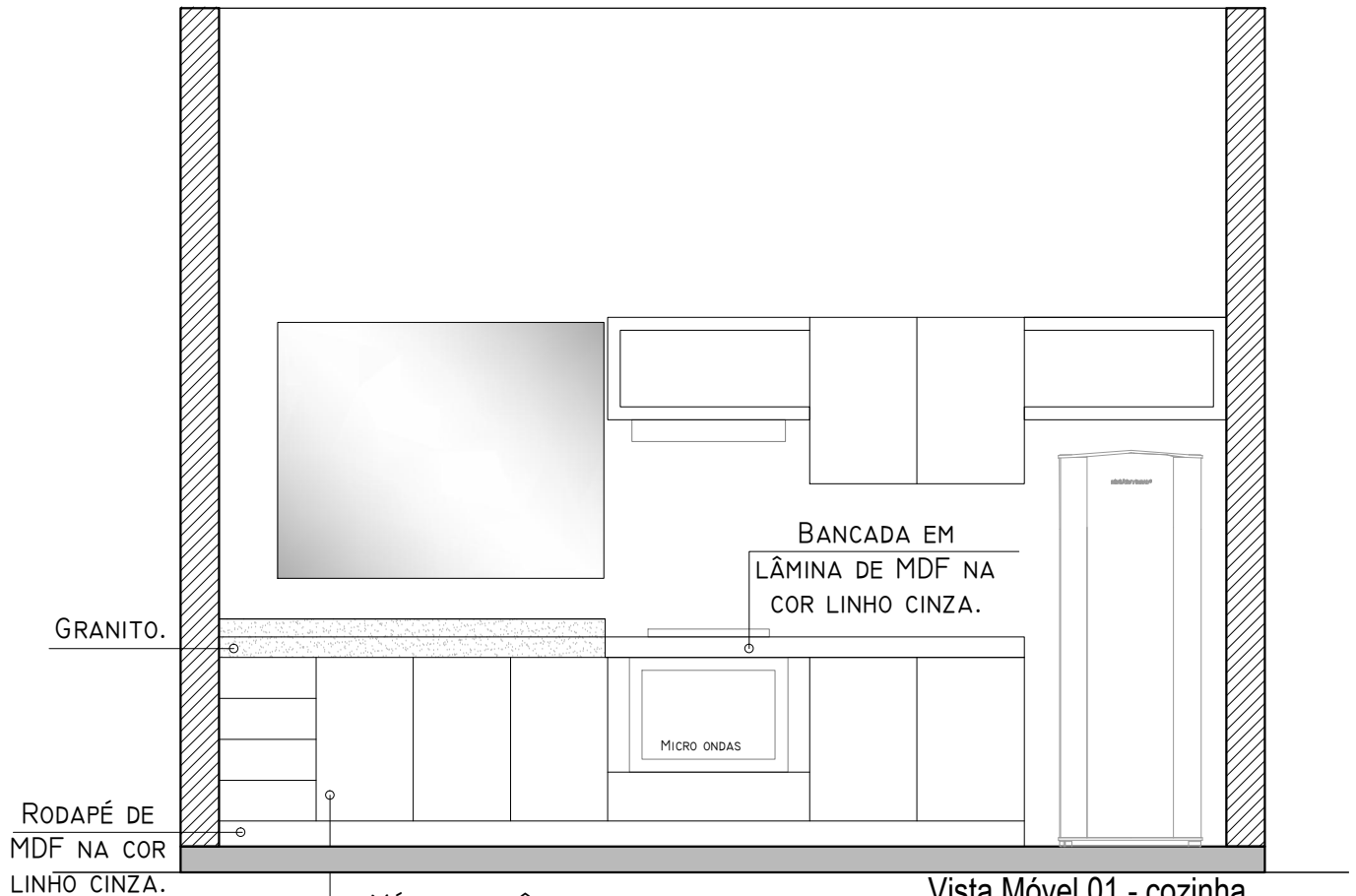

MÓVEL EM LÂMINA DE MDF NA COR LINHO CINZA. ABERTURA DAS PORTAS E GAVETAS PELO SISTEMA CLICK.

Vista Móvel 01 - cozinha



Projeto de Móveis - Câmara Municipal de Victor Graeff  
Cozinha- 44

Arquiteta e Urbanista Tábara V. Petry  
CAU A64875-2

Fone: 054 99172-0565 - email: arche\_arche@outlook.com - Av. Família Barth - 07 - Victor Graeff - RS



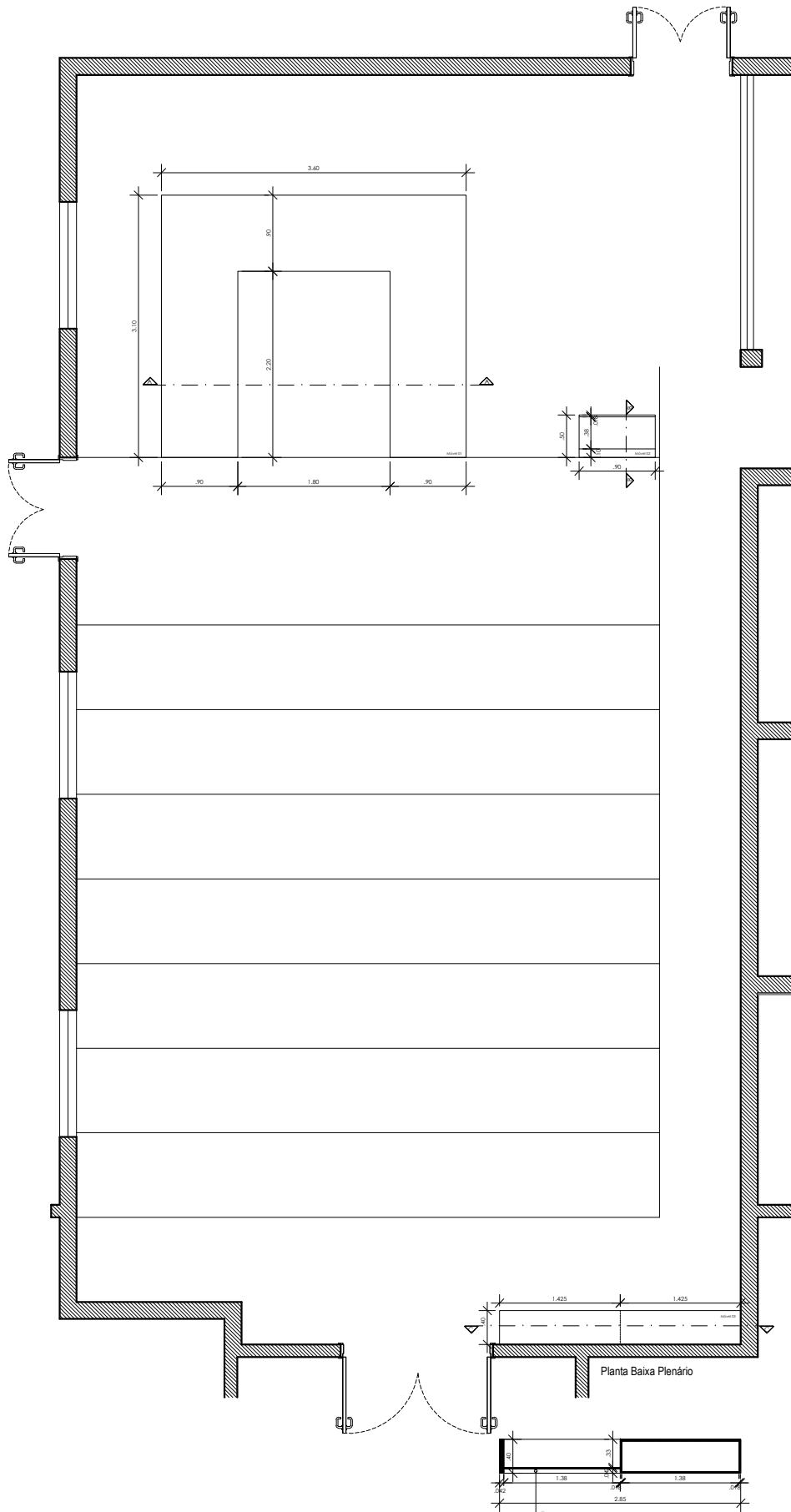

**Projeto de Móveis - Câmara Municipal de Victor Graeff  
Plenário- 45**

**Arquiteta e Urbanista Tábara V. Petry  
CAU A64875-2**

Fone: 054 99172-0565 - email: arche\_arche@outlook.com - Av. Família Barth - 07 - Victor Graeff - RS



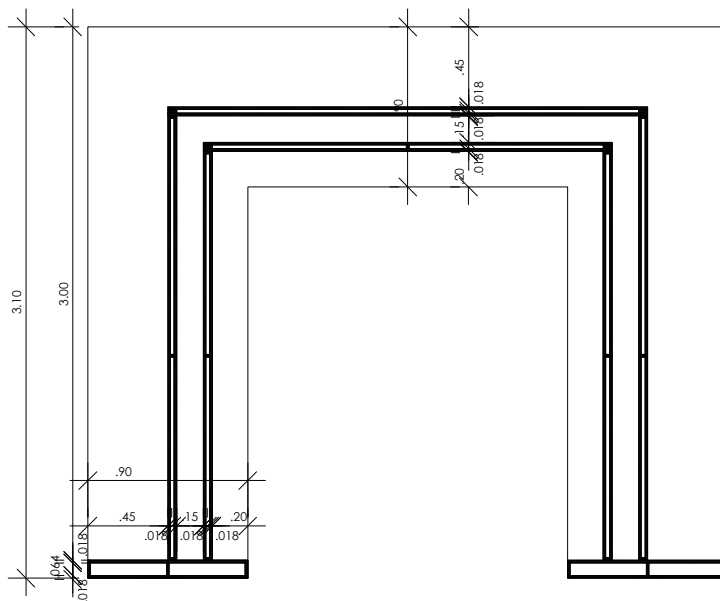
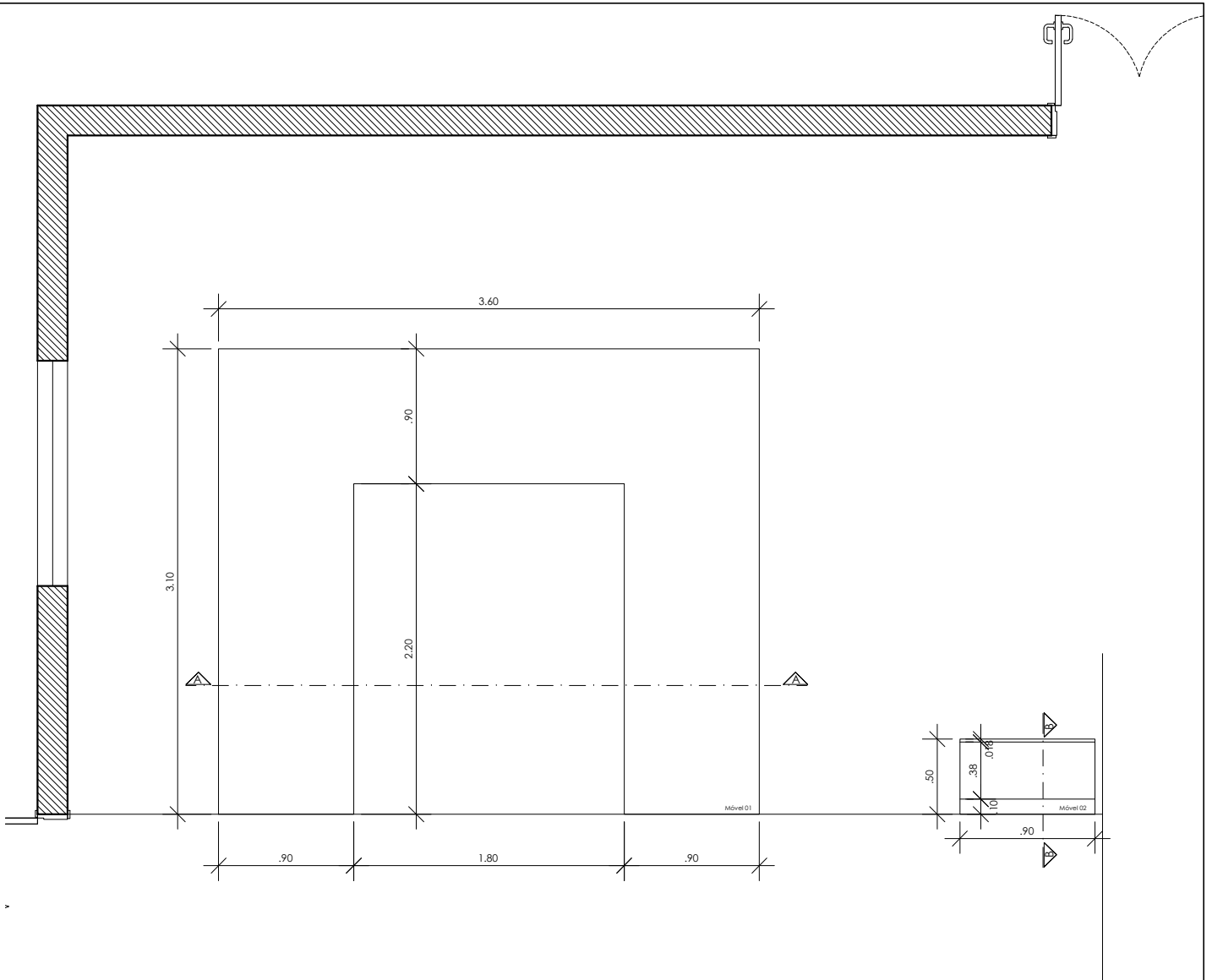

Projeto de Móveis - Câmara Municipal de Victor Graeff  
Plenário- 46

Arquiteta e Urbanista Tábora V. Petry  
CAU A64875-2

Fone: 054 99172-0565 - email: arche\_arche@outlook.com - Av. Família Barth - 07 - Victor Graeff - RS



FECHAMENTO DA  
MESA COM LÂMINA EM  
MDF AMADEIRADA.

TAMPO DA MESA E FECHAMENTO  
LATERAL COM LÂMINA EM MDF NA  
COR BRANCA LACA FOSCA.

AO REDOR DA LÂMINA AMADEIRADA  
ABAIXO DO TAMPO DA MESA IRA FITA LED  
PARA ILUMINAÇÃO DECORATIVA.

Corte AA Móvel 01 - Plenário

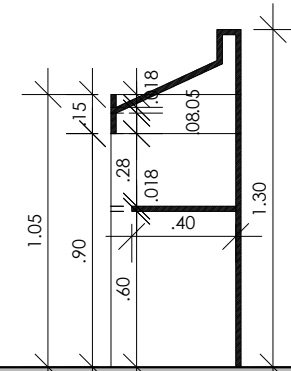

Corte BB Móvel 02 - Plenário

PÚLPITO. MÓVEL COM  
LÂMINA EM MDF NA COR  
BRANCA LACA FOSCA.

TAMPO DA MESA E  
FECHAMENTO LATERAL COM  
LÂMINA EM MDF NA COR  
BRANCA LACA FOSCA.

FECHAMENTO DA MESA COM  
LÂMINA EM MDF AMADEIRADA.

Vista Móvel 01 e 02- Plenário

Vista Móvel 02 - Plenário

Projeto de Móveis - Câmara Municipal de Victor Graeff  
Plenário- 47

Arquiteta e Urbanista Tábora V. Petry  
CAU A64875-2

Fone: 054 99172-0565 - email: arche\_arche@outlook.com - Av. Família Barth - 07 - Victor Graeff - RS



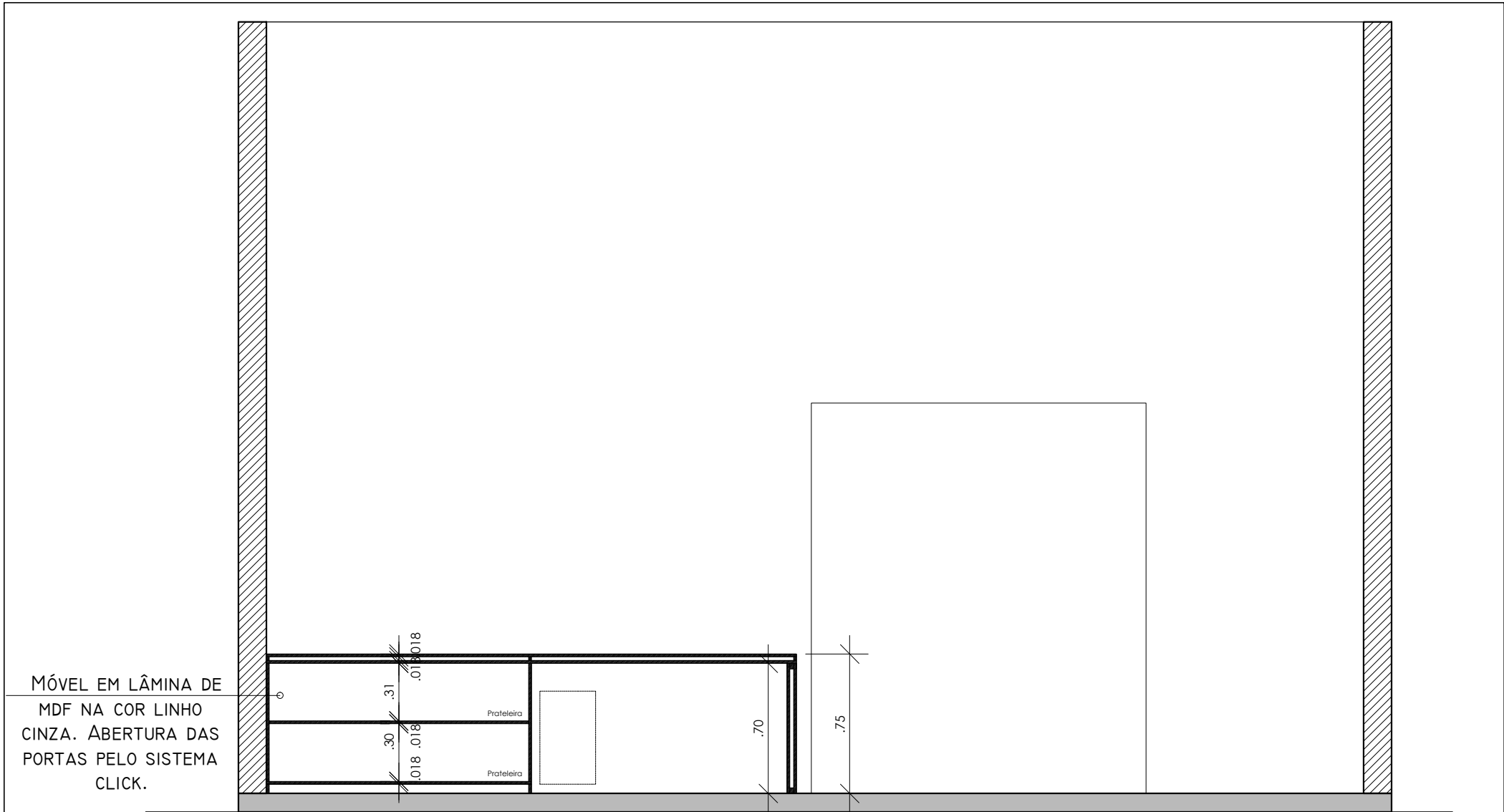

MÓVEL EM LÂMINA DE  
MDF NA COR LINHO  
CINZA. ABERTURA DAS  
PORTAS PELO SISTEMA  
CLICK.

Corte CC Móvel 03- Plenário

Projeto de Móveis - Câmara Municipal de Victor Graeff  
Plenário- 48

Arquiteta e Urbanista Tábara V. Petry  
CAU A64875-2

Fone: 054 99172-0565 - email: arche\_arche@outlook.com - Av. Família Barth - 07 - Victor Graeff - RS





MÓVEL EM LÂMINA DE  
MDF NA COR LINHO  
CINZA. ABERTURA DAS  
PORTAS PELO SISTEMA  
CLICK.

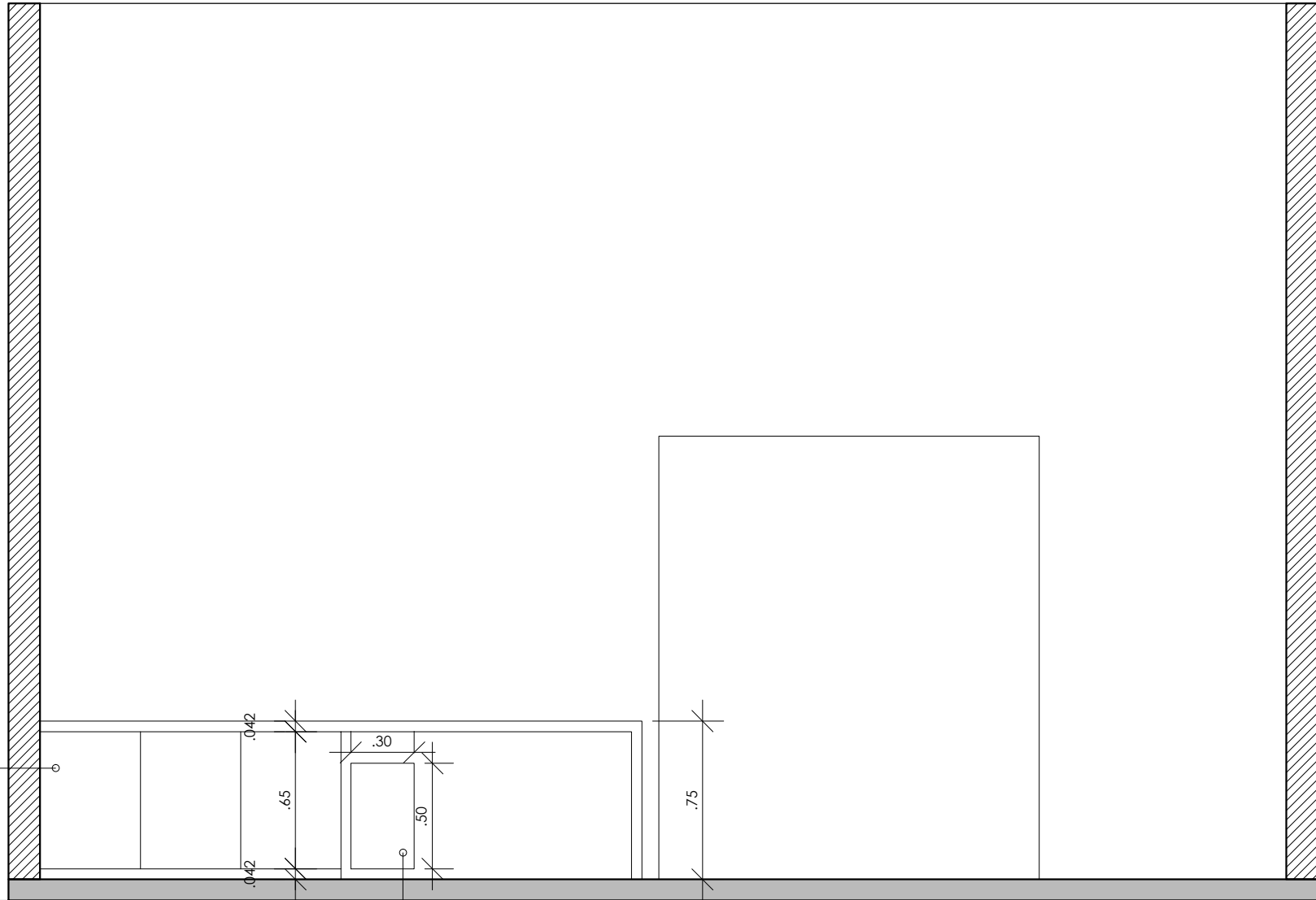

PAINEL COM UMA PORTA PARA ACESSO A  
FIAÇÃO. ABERTURA PELO SISTEMA CLICK.

Vista Móvel 03- Plenário

**Projeto de Móveis - Câmara Municipal de Victor Graeff  
Plenário- 49**

**Arquiteta e Urbanista Tábara V. Petry  
CAU A64875-2**

Fone: 054 99172-0565 - email: arche\_arche@outlook.com - Av. Família Barth - 07 - Victor Graeff - RS





Projeto de Móveis - Câmara Municipal de Victor Graeff  
Plenário - 50

Arquiteta e Urbanista Tábora V. Petry  
CAU A64875-2

Fone: 054 99172-0565 - email: arche\_arche@outlook.com - Av. Família Barth - 07 - Victor Graeff - RS





Projeto de Móveis - Câmara Municipal de Victor Graeff  
Plenário - 51

Arquiteta e Urbanista Tábara V. Petry  
CAU A64875-2

Fone: 054 99172-0565 - email: arche\_arche@outlook.com - Av. Família Barth - 07 - Victor Graeff - RS



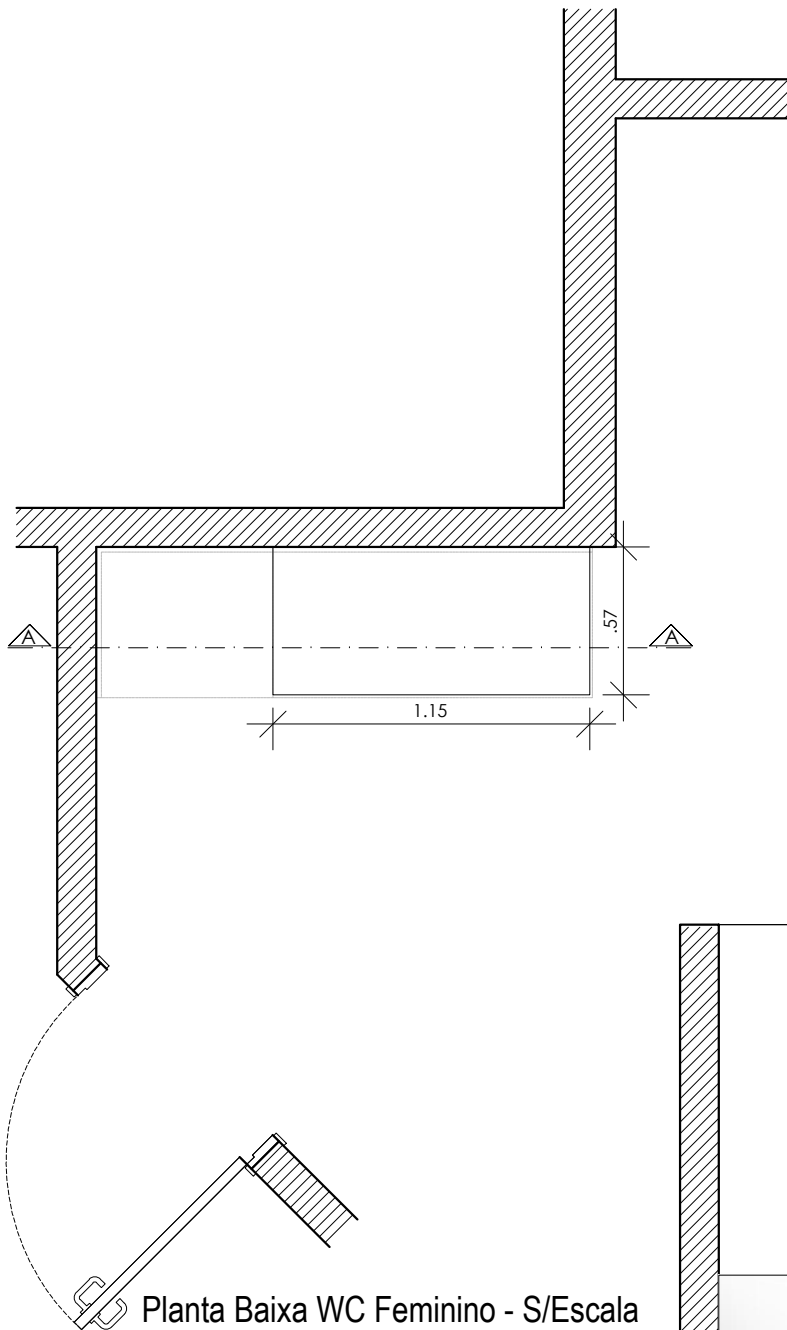

Planta Baixa WC Feminino - S/Escala

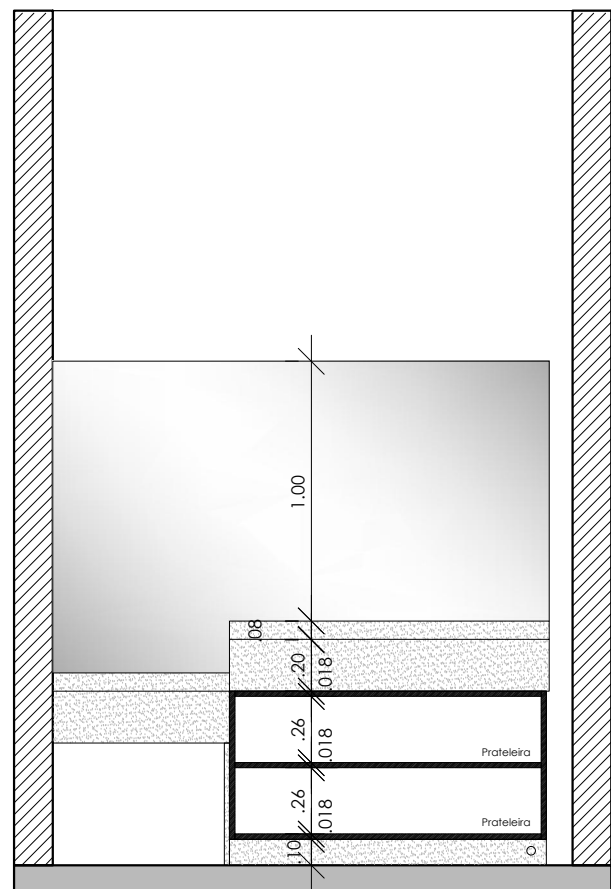

Corte AA WC Feminino

Projeto de Móveis - Câmara Municipal de Victor Graeff  
WC Feminino- 52

Arquiteta e Urbanista Tábara V. Petry  
CAU A64875-2

Fone: 054 99172-0565 - email: arche\_arche@outlook.com - Av. Família Barth - 07 - Victor Graeff - RS



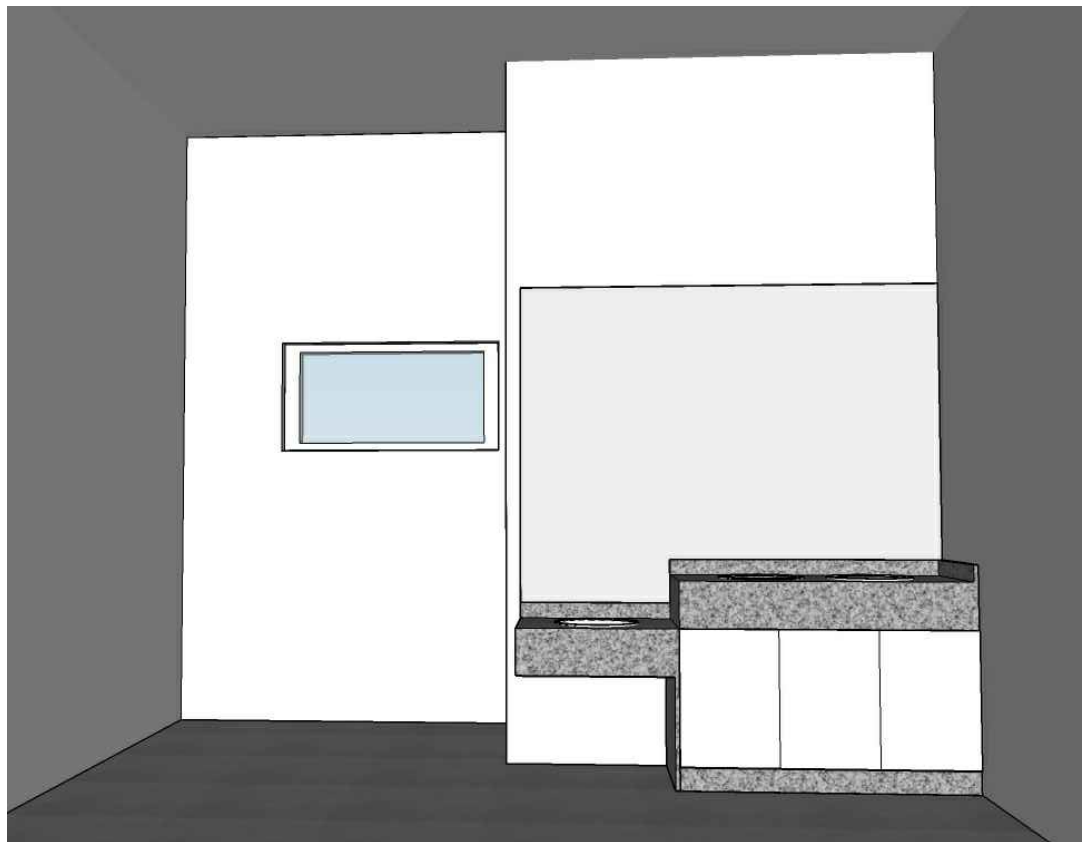
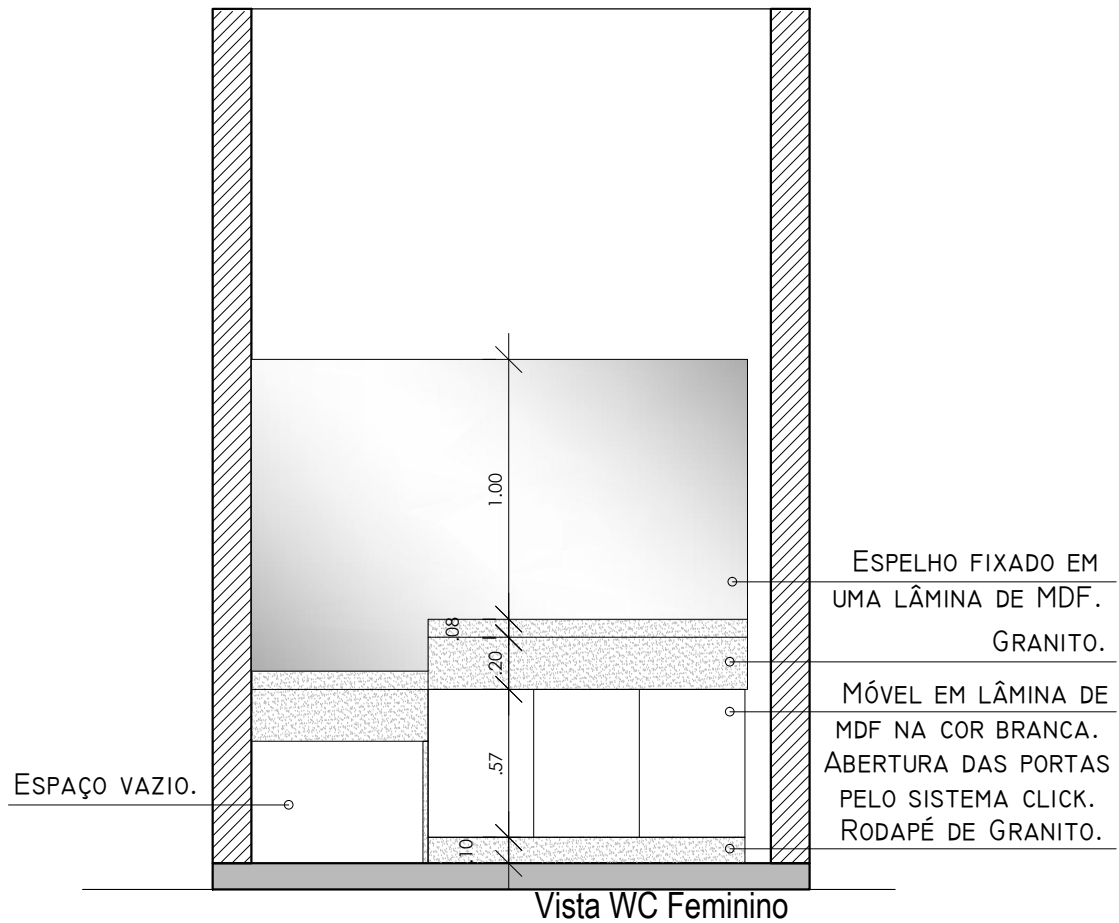

Projeto de Móveis - Câmara Municipal de Victor Graeff  
WC Feminino- 53

Arquiteta e Urbanista Tábara V. Petry  
CAU A64875-2

Fone: 054 99172-0565 - email: arche\_arche@outlook.com - Av. Família Barth - 07 - Victor Graeff - RS



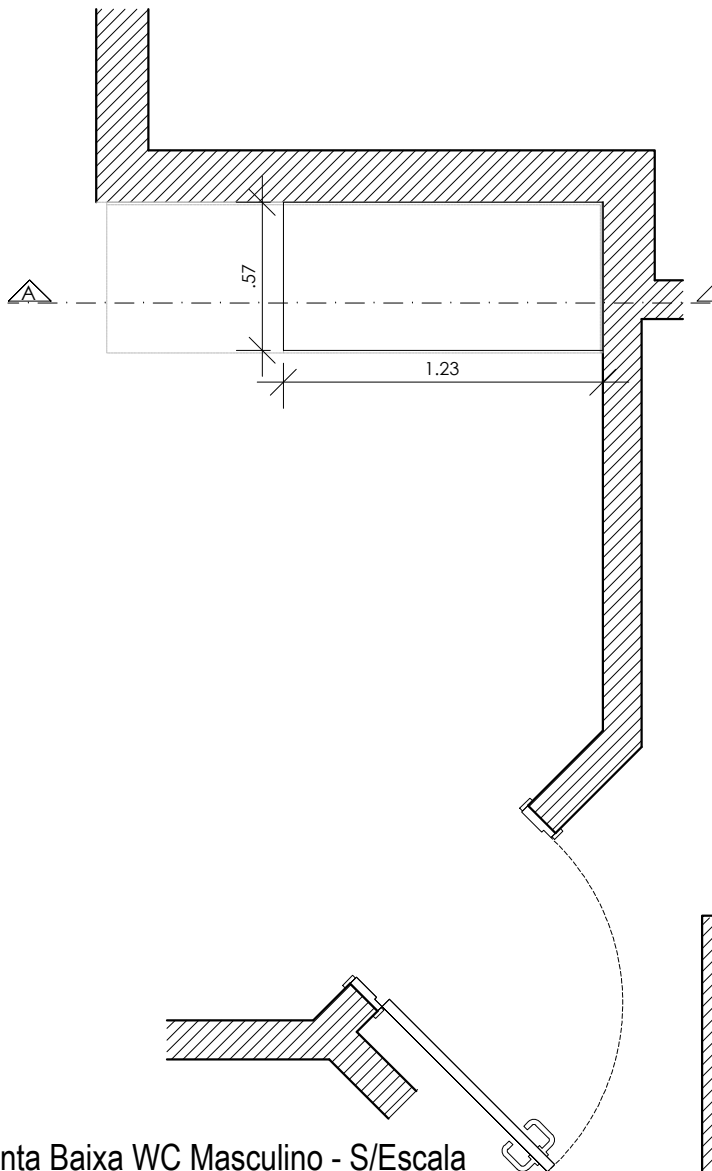

Planta Baixa WC Masculino - S/Escala

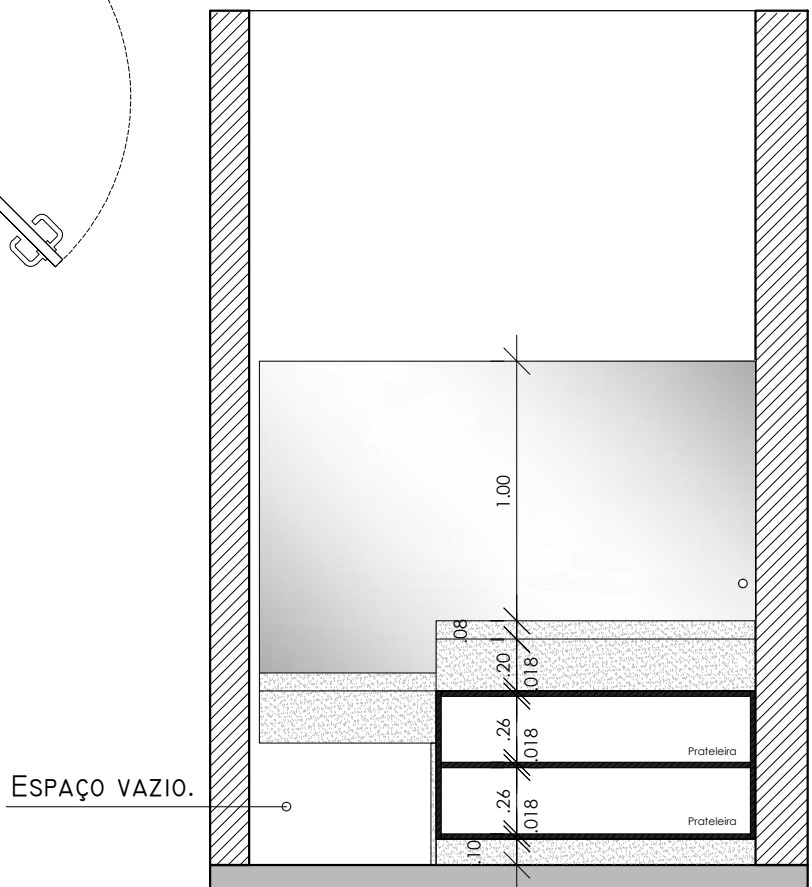

Corte AA WC Masculino

Projeto de Móveis - Câmara Municipal de Victor Graeff  
WC Masculino - 54

Arquiteta e Urbanista Tábara V. Petry  
CAU A64875-2

Fone: 054 99172-0565 - email: arche\_arche@outlook.com - Av. Família Barth - 07 - Victor Graeff - RS



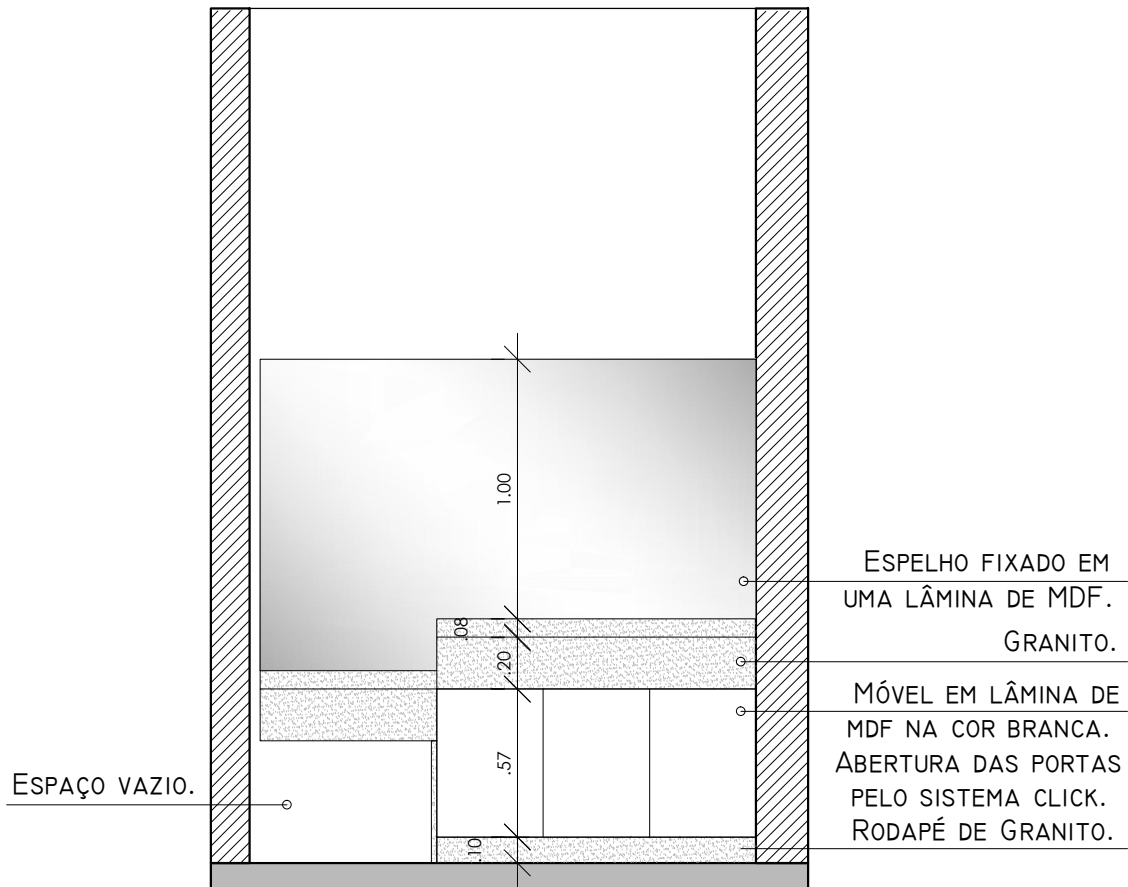

ESPELHO FIXADO EM  
 UMA LÂMINA DE MDF.  
 GRANITO.

MÓVEL EM LÂMINA DE  
 MDF NA COR BRANCA.  
 ABERTURA DAS PORTAS  
 PELO SISTEMA CLICK.  
 RODAPÉ DE GRANITO.

Vista WC Masculino

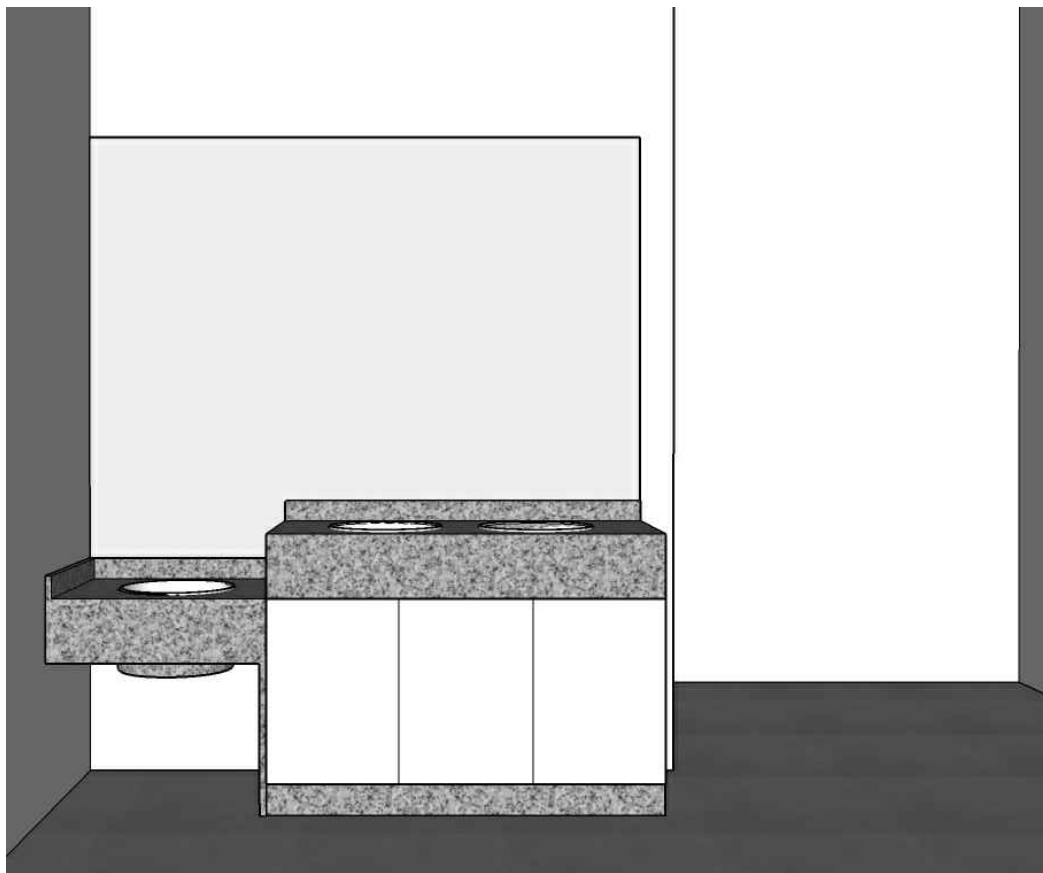

Projeto de Móveis - Câmara Municipal de Victor Graeff  
 WC Masculino - 55

Arquiteta e Urbanista Tábara V. Petry  
 CAU A64875-2

Fone: 054 99172-0565 - email: arche\_arche@outlook.com - Av. Família Barth - 07 - Victor Graeff - RS



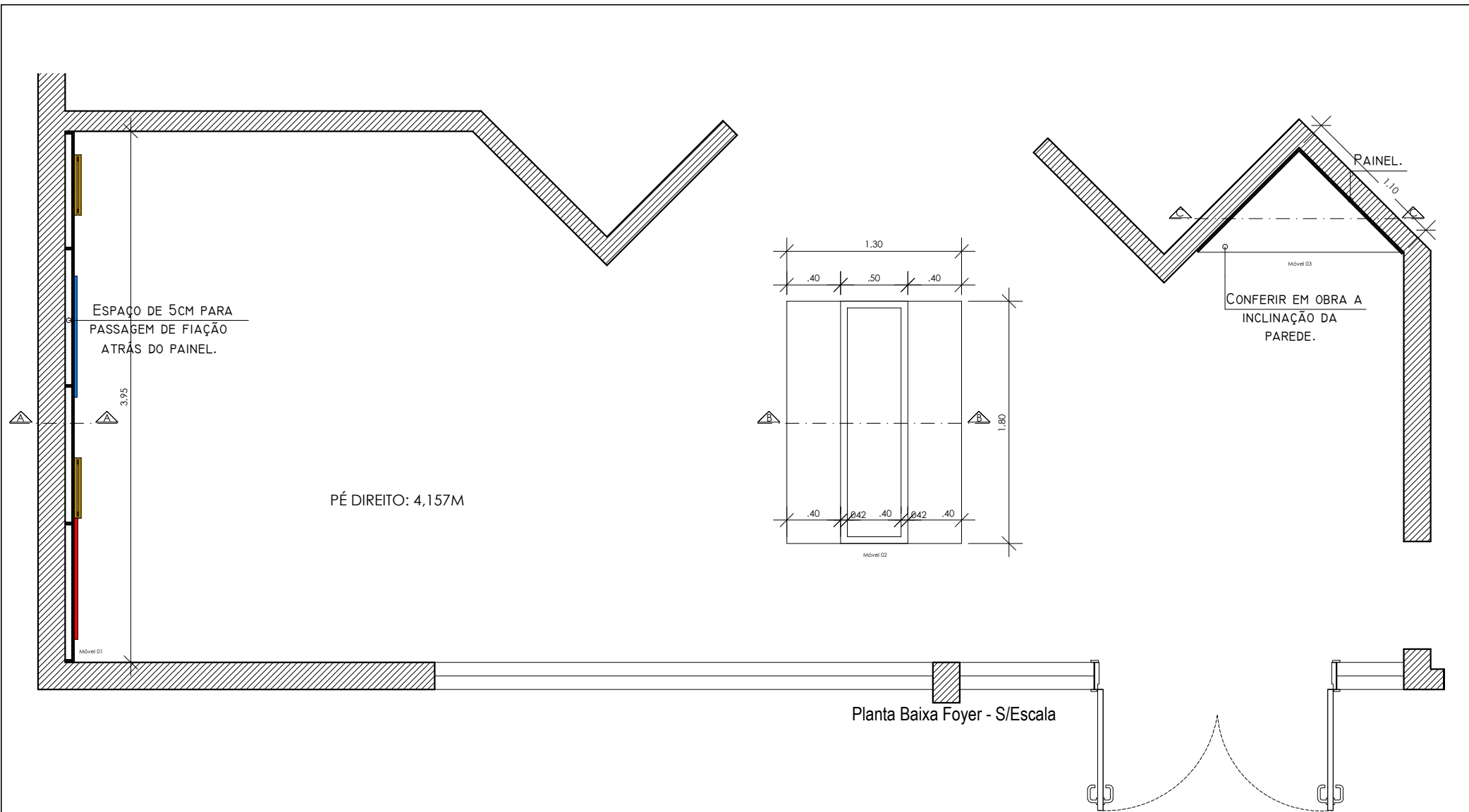

Projeto de Móveis - Câmara Municipal de Victor Graeff  
Foyer- 56

Arquiteta e Urbanista Tábora V. Petry  
CAU A64875-2

Fone: 054 99172-0565 - email: arche\_arche@outlook.com - Av. Família Barth - 07 - Victor Graeff - RS





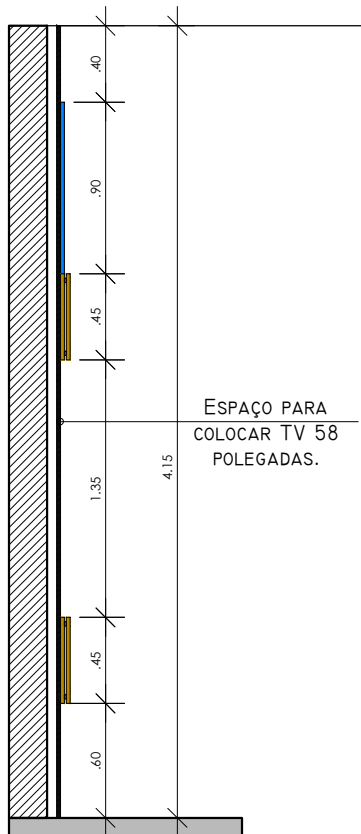

Corte AA Móvel 01 (Painel)- Foyer

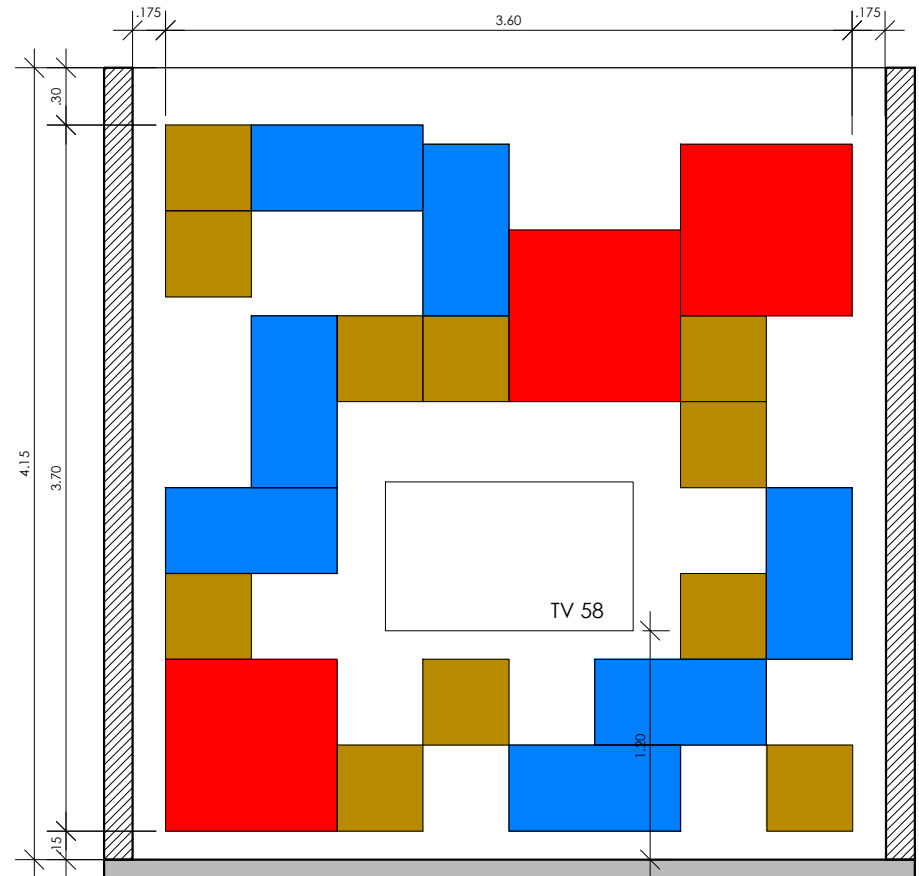

Vista Móvel 01(Painel)- Foyer

SOMENTE NA PLACA 45CMX45CM DE ESPESSURA DE 5CM SERÁ UTILIZADO ILUMINAÇÃO EM SEU CONTORNO COM FITA LED.

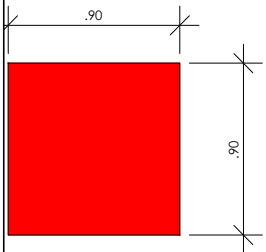

PLACA EM LÂMINA DE MDF NA COR AMADEIRADA. ESPESSURA DE 2,50CM.

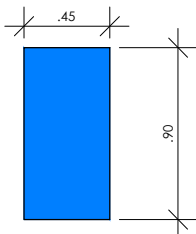

PLACA EM LÂMINA DE MDF NA COR AMADEIRADA. ESPESSURA DE 2CM.

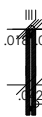
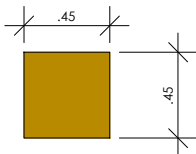

ESPAÇO PARA COLOCAR FITA LED AO REDOR DA LÂMINA. PLACA EM LÂMINA DE MDF NA COR AMADEIRADA. ESPESSURA DE 5CM.



Projeto de Móveis - Câmara Municipal de Victor Graeff Foyer- 57

Arquiteta e Urbanista Tábara V. Petry  
CAU A64875-2



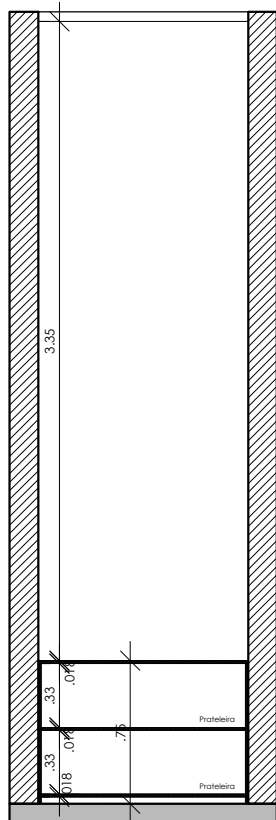

Corte CC Móvel 03- Foyer

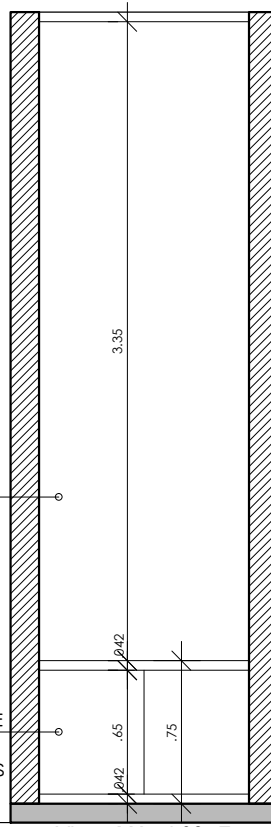

Vista Móvel 03- Foyer

PAINEL EM LÂMINA DE MDF AMADEIRADA.

MÓVEL EM LÂMINA DE MDF AMADEIRADA. ABERTURA DAS PORTAS PELO SISTEMA CLICK.

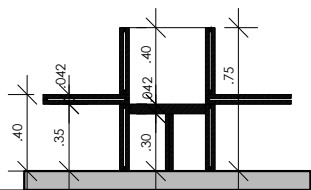
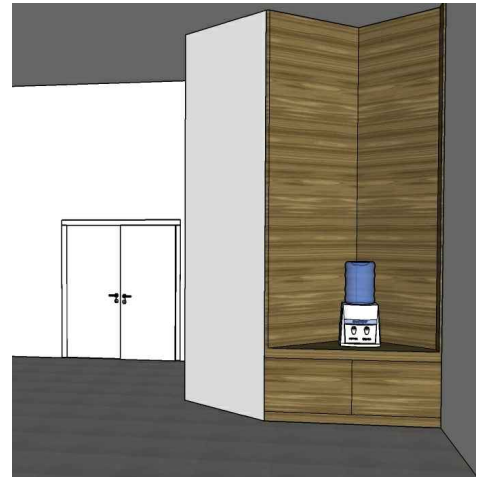

Corte BB Móvel 02- Foyer

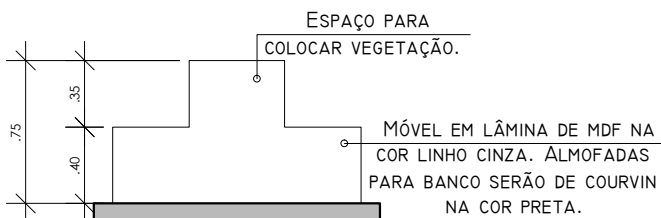

Vista Móvel 02- Foyer



Projeto de Móveis - Câmara Municipal de Victor Graeff  
Foyer- 58

Arquiteta e Urbanista Tábara V. Petry  
CAU A64875-2

Fone: 054 99172-0565 - email: arche\_arche@outlook.com - Av. Família Barth - 07 - Victor Graeff - RS



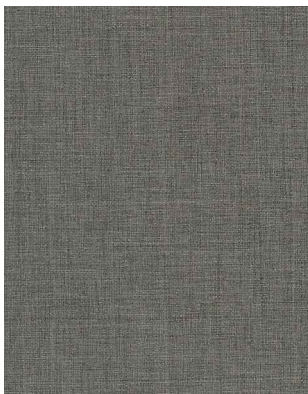

EXEMPLO DA LÂMINA DE MDF  
NA COR LINHO CINZA.

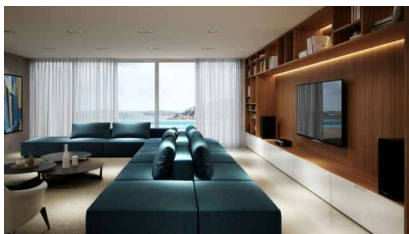

EXEMPLO DA LÂMINA DE MDF  
NA COR AMADEIRADA.

Para a execução dos móveis fazer e conferir as medidas de cada ambiente.  
Site dos eletrodomésticos utilizados:

[https://produto.mercadolivre.com.br/MLB-732266844-fogo-cooktop-fischer-4-bocas-gas-mesa-vidro-1519-5713-\\_JM?quantity=1&variation=32861611200](https://produto.mercadolivre.com.br/MLB-732266844-fogo-cooktop-fischer-4-bocas-gas-mesa-vidro-1519-5713-_JM?quantity=1&variation=32861611200)

[https://produto.mercadolivre.com.br/MLB-1063672860-depurador-de-ar-suggar-60cm-slim-\\_JM?quantity=1](https://produto.mercadolivre.com.br/MLB-1063672860-depurador-de-ar-suggar-60cm-slim-_JM?quantity=1)

[https://produto.mercadolivre.com.br/MLB-1053721945-micro-ondas-de-embutir-philco-pme25bm-25-litros-1400w-\\_JM?variation=27793005060&quantity=1#reco\\_item\\_pos=2&reco\\_backend=machinalis-v2p&reco\\_backend\\_type=low\\_level&reco\\_client=vip-v2p&reco\\_id=685248c6-0b89-473a-adf1-76f7af797a50](https://produto.mercadolivre.com.br/MLB-1053721945-micro-ondas-de-embutir-philco-pme25bm-25-litros-1400w-_JM?variation=27793005060&quantity=1#reco_item_pos=2&reco_backend=machinalis-v2p&reco_backend_type=low_level&reco_client=vip-v2p&reco_id=685248c6-0b89-473a-adf1-76f7af797a50)

Projeto de Móveis - Câmara Municipal de Victor Graeff  
Informações - 59

Arquiteta e Urbanista Tábora V. Petry  
CAU A64875-2

Fone: 054 99172-0565 - email: arche\_arche@outlook.com - Av. Família Barth - 07 - Victor Graeff - RS

